



TVBI TRASMITTENTI E SPECIALI

1939 - XVII

I

F. I. V. R. E.

FABBRICA ITALIANA VALVOLE RADIO ELETTRICHE
Società Anonima

SEDE SOCIALE E AMMINISTRAZIONE: **MILANO** - Corso Venezia, 13

STABILIMENTO I: **PAVIA** - Via Fabio Filzi, 1

STABILIMENTO II: **FIRENZE** - Via Panciatichi, 30

**DATI TECNICI DI ALCUNI TUBI
ELETTRONICI TRASMITTENTI
PRODOTTI DALLO
STABILIMENTO II° " F.I.V.R.E. ,,
DI FIRENZE**

Il presente catalogo non rispecchia tutta la produzione " F. I. V. R. E. ,, in tubi trasmettenti e speciali.

Si prega pertanto la Spett.^{le} Clientela di volerci sottoporre richieste e quesiti relativi alle proprie esigenze tecniche.

TUBI ELETTRONICI

TIPO	ACCENSIONE		1) Catodo	2) μ	$\mu_{1.2}$	S mA/V	3) CAPACITÀ INTERELETTRODICA			Dimensioni fig.	Placca Volt mass. c. c.	Scher- mo Volt mass. c. c.
	Volt	Amp.					Cgp C_{ga}	Cgf C_{gf}	Cpf C_{af}			
3 A 50	10	1.05	f. o.	10	—	3.5	5	9	5	1	1000	—
3 B 250	12.5	6.5	f. w.	25	—	1.2	7.5	6	1	2	4000	—
3 C 20	10.3	2.5	f. w.	29	—	0.9 [*]	5.2	7.5	2	3	1000	—
3 C 70	10	4.5	f. w.	31	—	1.7	3	9	3.5	4	1600	—
3 C 300	12.5	6.5	f. wt.	22	—	1.6	4	5	1.2	5	3000	—
4 C 15	4	1.15	f. o.	70	8.5	1.7 [*]	0.03	12.5	8.5	6	600	250
5 C 10	4	0.65	f. o.	200	4.5	2 [*]	0.03	12	9	7	400	200
5 C 15	4	1.05	f. o.	230	4.8	2.6	0.02	13.5	10	8	600	200
5 C 100 5 C 100 P	12 9	2.7 3	f. wt.	500	2.8	1.75	0.03 0.03	15 28	18 18	9 a 9 b	1500	500
5 C 500	12	10	f. wt.	200	3.5	5 [*]	0.15	35	28	10	3000	600
4 C 100	12	3	f. wt.	200	4.6	3.2	0.08	16.5	17.5	9 a	1500	500
4 C 500	12	10	f. wt.	500	5.5	10 [*]	0.15	35	28	10	3000	600

TRASMITTENTI "FIVRE,"

Dis- paz. placca mass. Watt	Dissip. scher. mass. w	4) Servizio	Placca Volt c. c.	Soppres. Volt c.c.	Scher- mo Volt c. c.	Griglia Volt c. c.	Placca mAmp. c. c.	Poten- za eccitaz. Watt	Poten- za utile Watt	OSSERVAZIONI
75	—	B bf.	1000	—	—	- 100	250	4	170	Rpp = 9300 Ω 5)
		C tg.	1000	—	—	- 150	120	5	90	
		C tf.	750	—	—	- 130	98	6	55	
250	—	C tg.	4000	—	—	- 320	100	8	300	
		C tf.	3000	—	—	- 360	70	12	160	
20	—	C tg.	1000	—	—	- 125	45	3	30	* S a 20 mA
		C tf.	1000	—	—	- 150	30	4	22	
70	—	C tg.	1600	—	—	- 135	65	4	75	
		C tf.	1400	—	—	- 170	50	6	45	
300	—	B bf.	3000	—	—	- 125	600	30	1200	Rpp = 11300 Ω Valvola adatta per freq. alte
		C tg.	3000	—	—	- 330	320	35	700	
		C tf.	2500	—	—	- 530	290	40	500	
18	4	C tg	600	—	250	- 70	50	1.5	13	* S a 30 mA
10	3	C tg.	400	0	200	- 90	40	0.4	8.5	* S a 30 mA Modulare anche sullo schermo
		C tf.	350	0	180	- 100	30	0.6	5	
15	3	C tg.	600	0	200	- 100	60	1	24	Modulare anche sullo schermo
		C tf	500	0	200	- 140	50	1	16.5	
100	25	C tg.	1500	0	500	- 270	150	1.8	160	Modulare anche sullo schermo
		C tf.	1250	0	400	- 300	130	2.2	120	
400	60	B rf.	3000	0	600	- 180	250	3.5	260	P _a = 260 W P _u = 750 W P _o = 490 W Condizioni massime Modulare anche sullo schermo
		C tg.	3000	0	600	- 330	400	3.5	900	
		C tf.	2500	0	400	- 360	280	4	560	
100	20	C tg.	1500	0	500	- 200	150	1	160	Tetrodo a fascio elettronico Modulare anche sullo schermo
		C tf.	1250	0	400	- 230	130	1.5	120	
400	60	B rf.	3000	0	600	- 110	250	2	260	Tetrodo a fascio elettronico Modulare anche sullo schermo
		C tg.	3000	0	600	- 180	400	2	900	
		C tf.	2500	0	400	- 150	280	3	560	

TUBI ELETTRONICI

(CORRISPONDENTI AI TIPI)

TIPO	ACCENSIONE		Catodo	1)	2)	S mA/V	3) CAPACITÀ INTERELETTRODICA			Dimensioni fig.	Placca Volt mass. c. c.	Scherm mo Volt mass. c. c.
	Volt	Amp.		μ	μ_{1-2}		Cgp	Cgf	Cpf			
203 A	10	3.25	f. wt.	25	—	3.4	14.5	6.5	5.5	11	1250	—
211	10	3.25	f. wt.	12	—	3.15	14.5	6	5.5	11	1250	—
805	10	3.25	f. wt.	variab. (circa 48)	—	4.2 [*]	6.5	8.5	10.5	12	1500	—
806	5	10	f. wt.	12.6	—	2	3.4	6.1	1.1	13	3000	—
807	6.3	0.9	c. o.	10	135	6 [*]	0.2	11	7	14	600	300
834	7.5	3.25	f. wt.	10.5	—	2	2.6	2.2	0.2	15	1250	—
845	10	3.25	f. wt.	5.3	—	2.5	13.5	6	6.5	11	1250	—
849	11	5	f. wt.	19	—	5.8 [*]	33.5	17	3	16	3000	—

TRASMITTENTI "FIVRE",

R C A (DI UGUALE DENOMINAZIONE)

Dissipaz. Placca mass. W	Dissip.scher.mass.w	4) Servizio	Placca Volt c. c.	Soppress Volt c. c.	Scher-mo Volt c. c.	Griglia Volt c. c.	Placca mAmp. c. c.	Poten-za eccitaz. Watt	Poten-za utile Watt	OSSERVAZIONI
100	—	B bf. C tg. C tf.	1250 1250 1000	— — —	— — —	- 45 - 125 - 135	320 170 150	11 8 4	260 160 100	Rpp = 9000 Ω 5)
100	—	B bf. C tg. C tf.	1250 1250 1000	— — —	— — —	- 100 - 200 - 260	320 170 150	8 8 14	260 160 100	Rpp = 9000 Ω
125	—	B bf. C tg. C tf.	1500 1500 1250	— — —	— — —	- 16 - 105 - 160	400 200 160	7 8.5 16	370 215 140	Rpp = 8200 Ω * S a 75 mA
150	—	B bf. C tg. C tf.	3000 3000 2500	— — —	— — —	- 240 - 600 - 600	330 195 195	10 20 32	660 450 390	Rpp = 21500 Ω
25	2.5	C tg. C tf.	600 475	0 0	250 225	- 50 - 50	100 83	0.2 0.1	37 24	Tetrodo a fascio elettronico Modulare anche sullo schermo * S a 75 mA
50	—	C tg. C tf.	1250 1000	— —	— —	- 225 - 310	90 90 ?	4.5 6.5	75 58	Adatta per frequenze elevate
75	—	B bf.	1250	—	—	- 225	200	—	105	Rpp = 8800 Ω
400	—	B bf. B rf. C tg. C tf.	3000 2500 2500 2000	— — — —	— — — —	- 155 - 125 - 250 - 300	520 210 300 300 ?	16 12 8 14	1100 180 560 425	Rpp = 12800 Ω * S a 100 mA

TUBI ELETTRONICI TRASMITTENTI

(CORRISPONDENTI AI TIPI)

TIPO	ACCENSIONE		Catodo	μ	S mA/V	CAPACITÀ INTERELETTRODICA			Dimensioni fig.	Placca Volt mass c. c.	Dissi- pazione placca mass. KW
	Volt	Amp.				Cgp	Cgf	Cpf			
207	22	52	fw	20	5.7 *	27	18	2	22	15000	10
846	11	51	fw	40	2.15 *	9	6.5	1.5	23	7500	2.5
858	22	52	fw	42	4.8 *	18	16	2	24	20000	20
892	22	60	fw	50	7 *	27	18	2	25	15000	10

DIODI RADDRIZZATORI

TIPO	ACCENSIONE		Corrente anodica c. c. Amp.	Cresta cor- rente ano- dica Amp.	Cresta ten- sione in- versa V	Tempera- tura mer- curio con- densato C°	Dimen- sioni fig.
	Volt	Amp.					
866 A 866 B	2.5	5	0.25	1	10.000	20° — 60°	17 18
869 A	5	18	2.5	10	20.000	15° — 50°	19
872 A 872 G	5	7	1.25	5	10.000	20° — 60°	20 21

"FIVRE,, RAFFREDDATI AD ACQUA

R C A DI UGUALE DENOMINAZIONE)

Servizio	Placca Volt c. c.	Griglia Volt c. c.	Placca Amp. c. c.	Potenza eccitaz W	Potenza utile KW	OSSERVAZIONI
B bf. B rf. C tg. C tf.	12500 14000 12000 10000	- 575 - 650 1600 - 2000	2.8 1 1.67 0.75	400 0 235 185	22.5 4 15 6	Rpp = 10000 Ω * S a 750 mA
B rf. C tg. C tf.	7000 7000 6000	- 100 - 900 - 950	0.45 0.9 0.5	175 300 200	1 4.25 2.25	* S a 750 mA
B bf. B rf. C tg. C tf.	12000 18000 18000 12000	140 - 300 - 1200 1000	3.6 0.9 1.8 0.95	115 85 250 150	26.5 5.6 22.4 8	Rpp = 7200 Ω * S a 750 mA
B bf. B rf. C tg. C tf.	12500 14000 12000 10000	- 200 - 220 - 1600 - 1600	2.8 0.95 1.64 0.72	420 30 500 260	22 4 14 6	Rpp = 10000 Ω * S a 750 mA Il filamento è formato da due unità in serie che possono essere alimentate separatamente con fasi diverse e tensione di 11 V.

A VAPORI DI MERCURIO

OSSERVAZIONI

La caduta di tensione interna è in media di 12 Volt.

Il filamento deve essere acceso almeno un minuto prima di dar tensione alla placca.

Il mercurio deve essere condensato in basso, se non lo fosse tenere acceso il filamento 15 ÷ 30 minuti.

S P I E G A Z I O N I

- 1) c. = catodo a riscaldamento indiretto
 f. = filamento a riscaldamento diretto
 o. = ad ossidi
 w. = in tungsteno puro
 wt. = in tungsteno toriato

$$2) \quad \mu = \frac{\delta E_a}{\delta E_{g_1}} \quad \mu^{1-2} = \frac{\delta E_{g_2}}{\delta E_{g_1}}$$

S = Conduttanza mutua: è misurata a 50 mA di corrente anodica, a meno che non sia diversamente indicato nelle osservazioni (*).

- 3) Per i triodi le capacità indicate sono quelle dirette.
 Per le valvole a griglia schermo, con o senza soppressore, C_{g-p} è misurata con valvola schermata esternamente (nella parte inferiore) o con virola metallica collegata a terra; C_{g-f} e C_{p-f} sono le capacità statiche d'entrata e d'uscita.
- 4) **B bf.** = Amplificatore classe B per bassa frequenza, modulatore.
 Per questo funzionamento i dati si riferiscono a due valvole montate in controfase.
B rf. = Amplificatore classe B per radio frequenza modulata.
 La potenza d'eccitazione si riferisce alla cresta di modulazione.
C tg. = Amplificatore classe C, telegrafia.
C tf. = " " " telefonia con modulazione anodica, condizioni per la portante.
- 5) R_{pp} = Resistenza di carico fra placca e placca per **B bf.**

Quando si parla di modulazione ci si riferisce alle condizioni teoriche di $m = 1$ ed onda sinusoidale.

RAFFRONTO TRA I TUBI ELETTRONICI " FIVRE ,, E QUELLI DELLA CONCORRENZA

TIPO FIVRE	TIPI DELLA CONCORRENZA PERFETTAMENTE SOSTITUIBILI	TIPI DELLA CONCORRENZA SIMILI
3 A 50	Philips MC. 1/50	Telefunken R S 243, R S 237
3 B 250	Marconi T 250, Philips TA 4/250 S	
3 C 20	Telefunken R S 69, Philips W 69	
3 C 70	Telefunken R S 31, Philips W 31	
3 C 300	R C A 833
4 C 15	Philips W 15 S	
5 C 10	R C A 802
5 C 15	Philips P C 05/15	
5 C 100	Marconi P 125	{ R C A 803, Raytheon R K 28 Telefunken R S 337
5 C 100 P	Philips P C 1,5/100	
5 C 500	Telefunken R S 384 Marconi P 400	
4 C 100	*	R C A 813, Raytheon R K 48
4 C 500	*	

* I due tetrodi a fascio elettronico possono essere praticamente montati su tutti gli apparecchi che abbiano il tipo corrispondente con soppressore (5 C 100, 5 C 500), purchè naturalmente detto soppressore sia collegato al catodo.

DIMENSIONI DEI TUBI TRASMETTENTI « FIVRE »

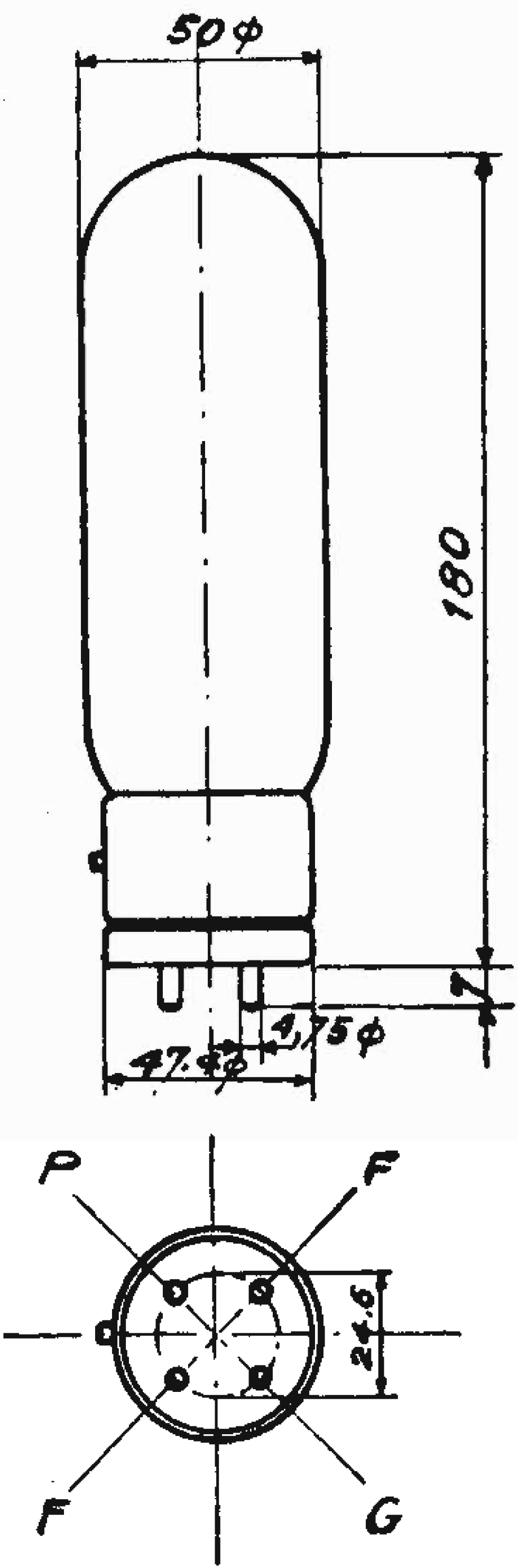

Fig. 1

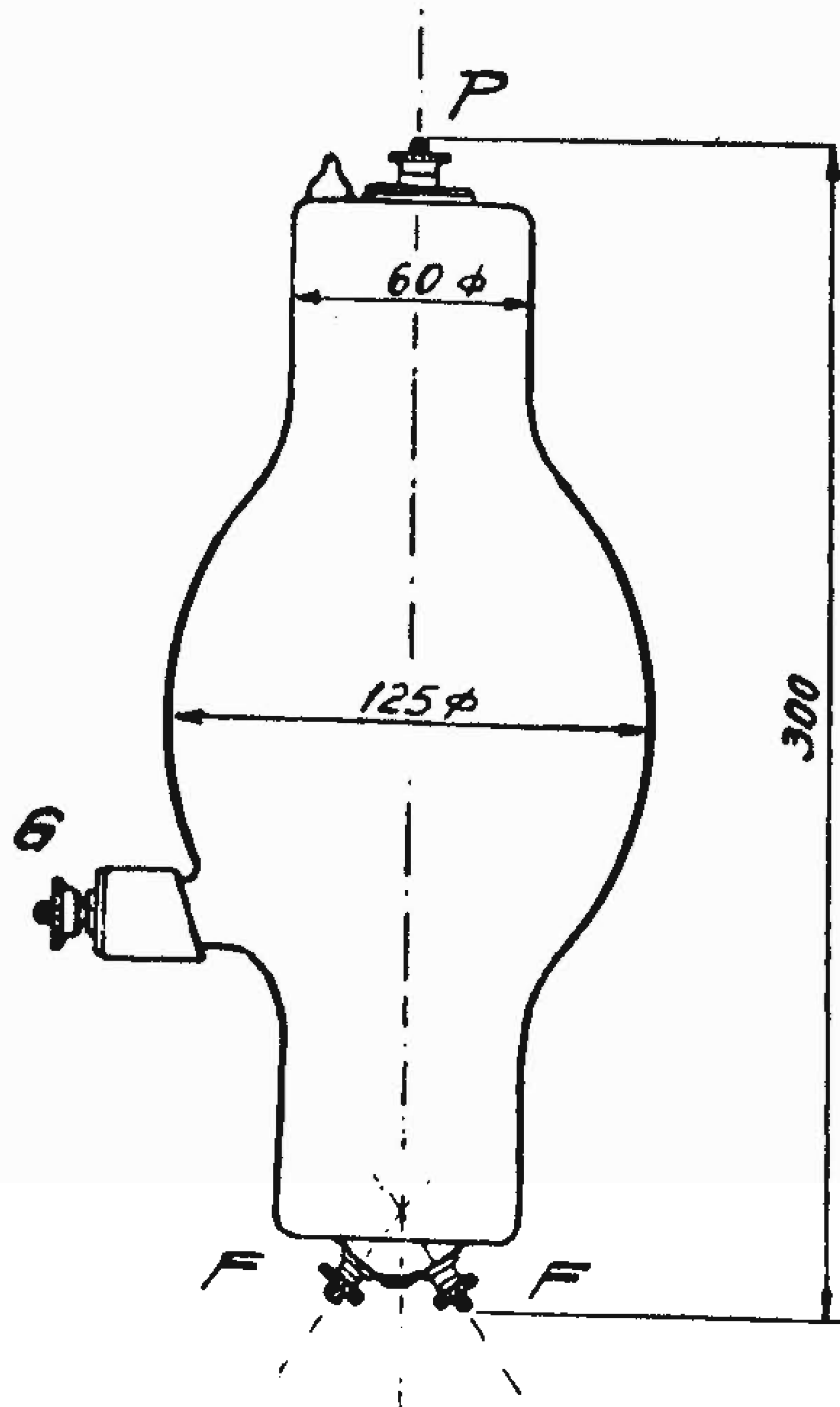

Fig. 2

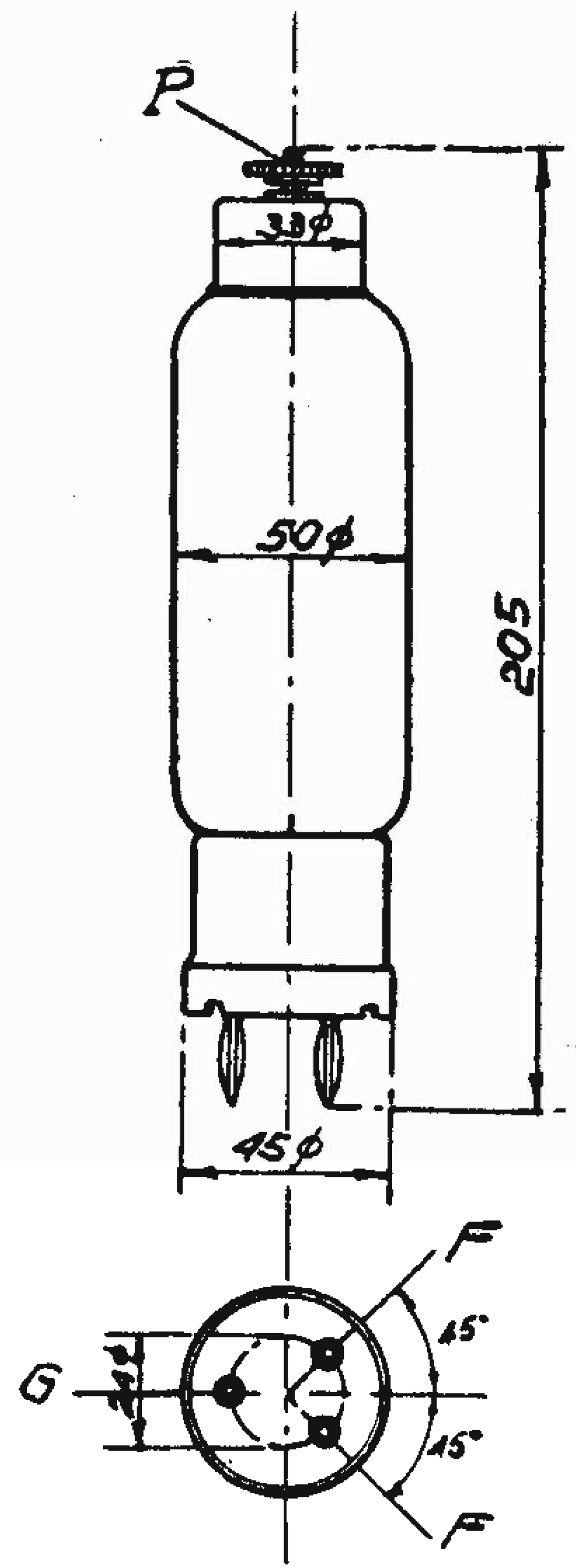

Fig. 3

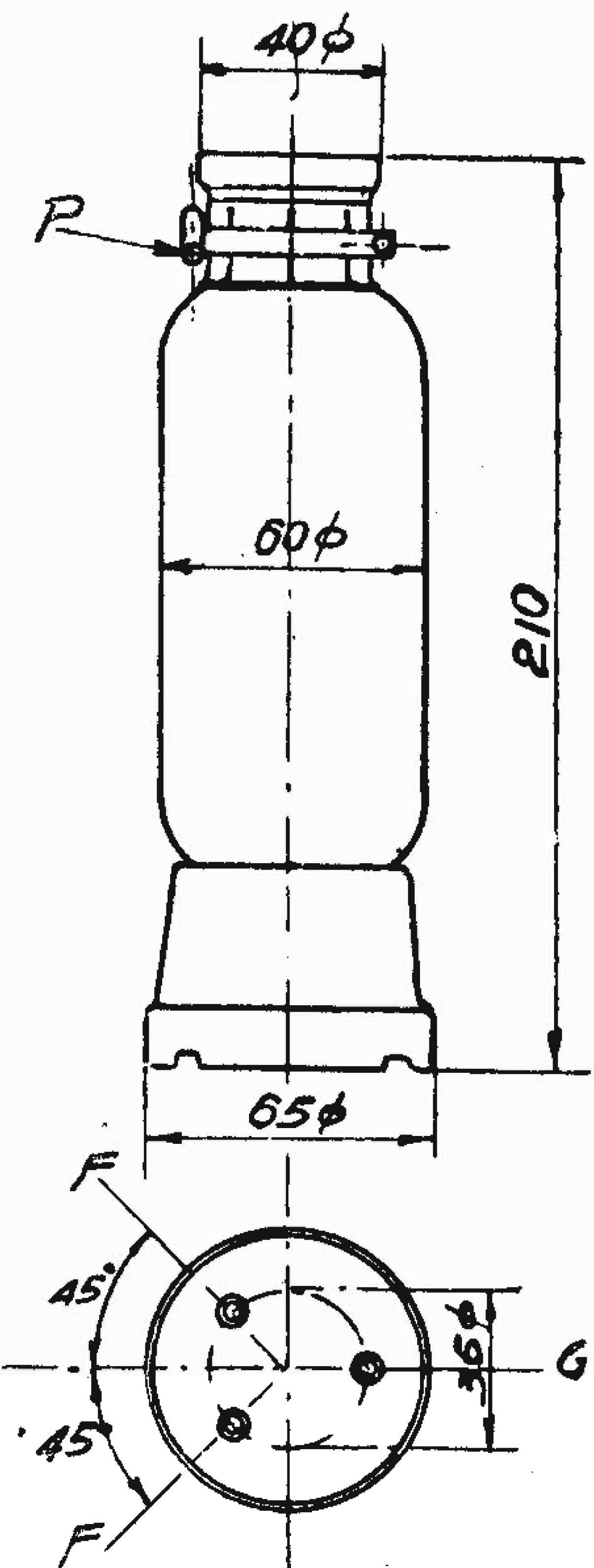

Fig. 4

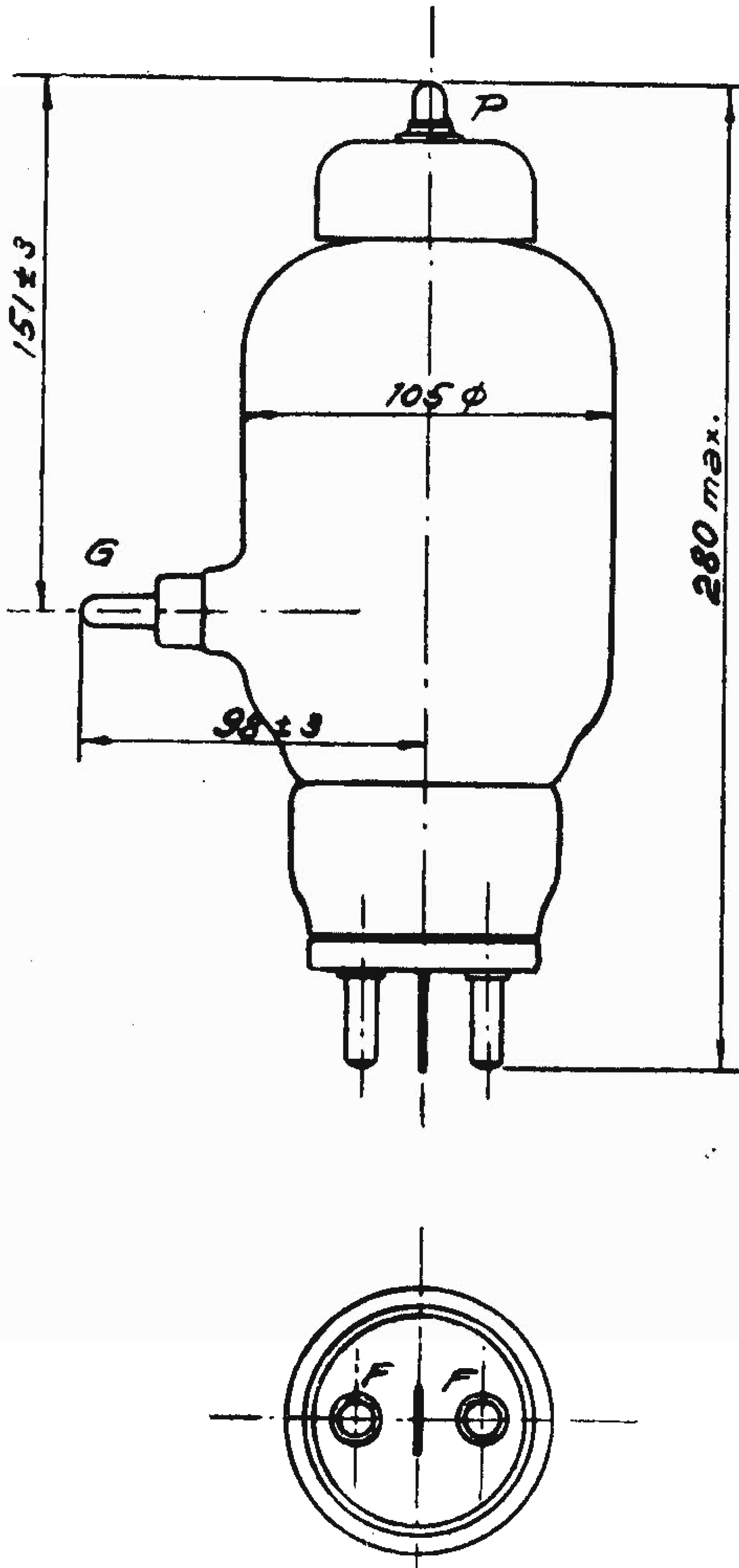

Fig. 5

DIMENSIONI DEI TUBI TRASMITTENTI « FIVRE »

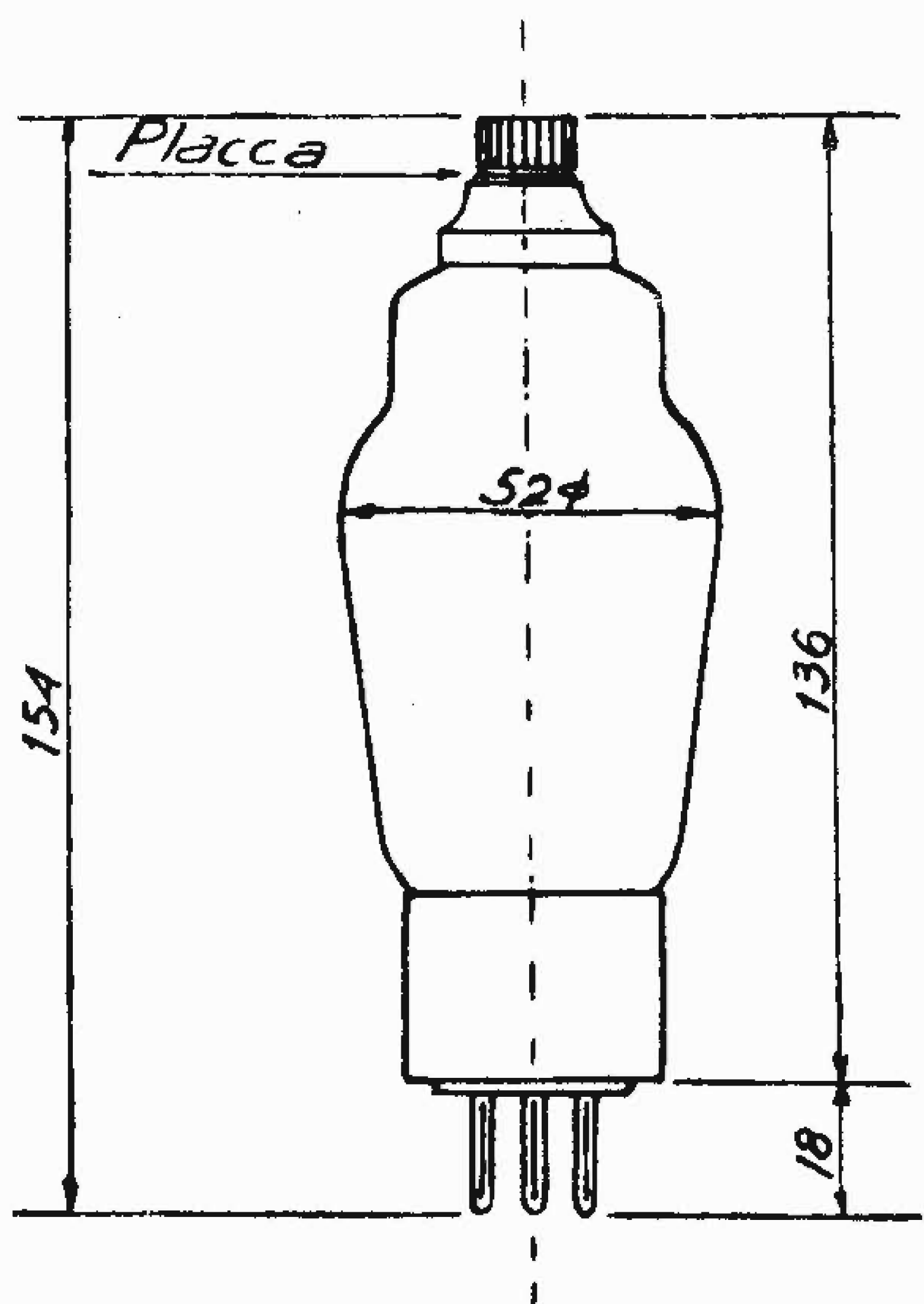

Fig. 6

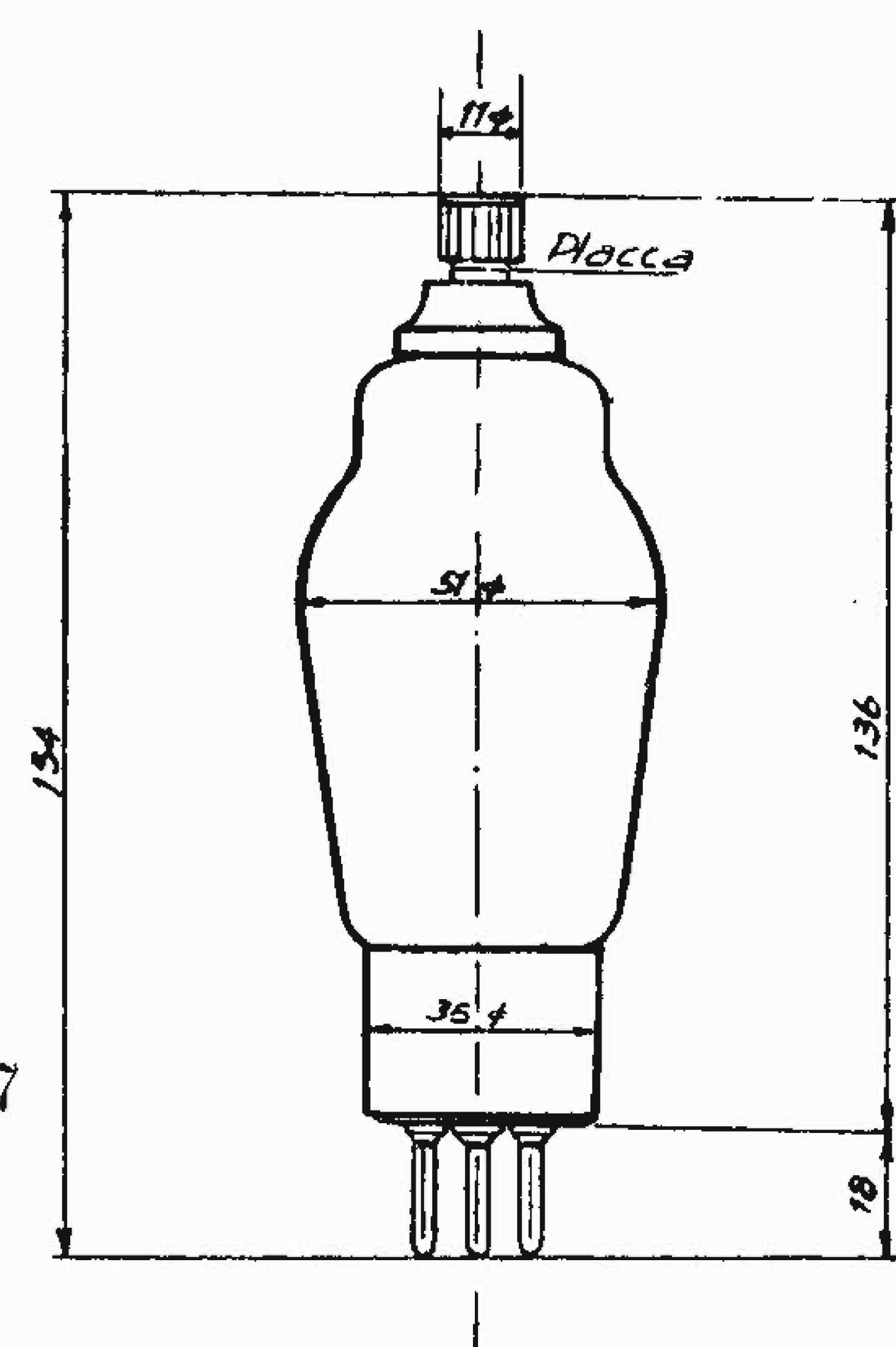

Fig. 7

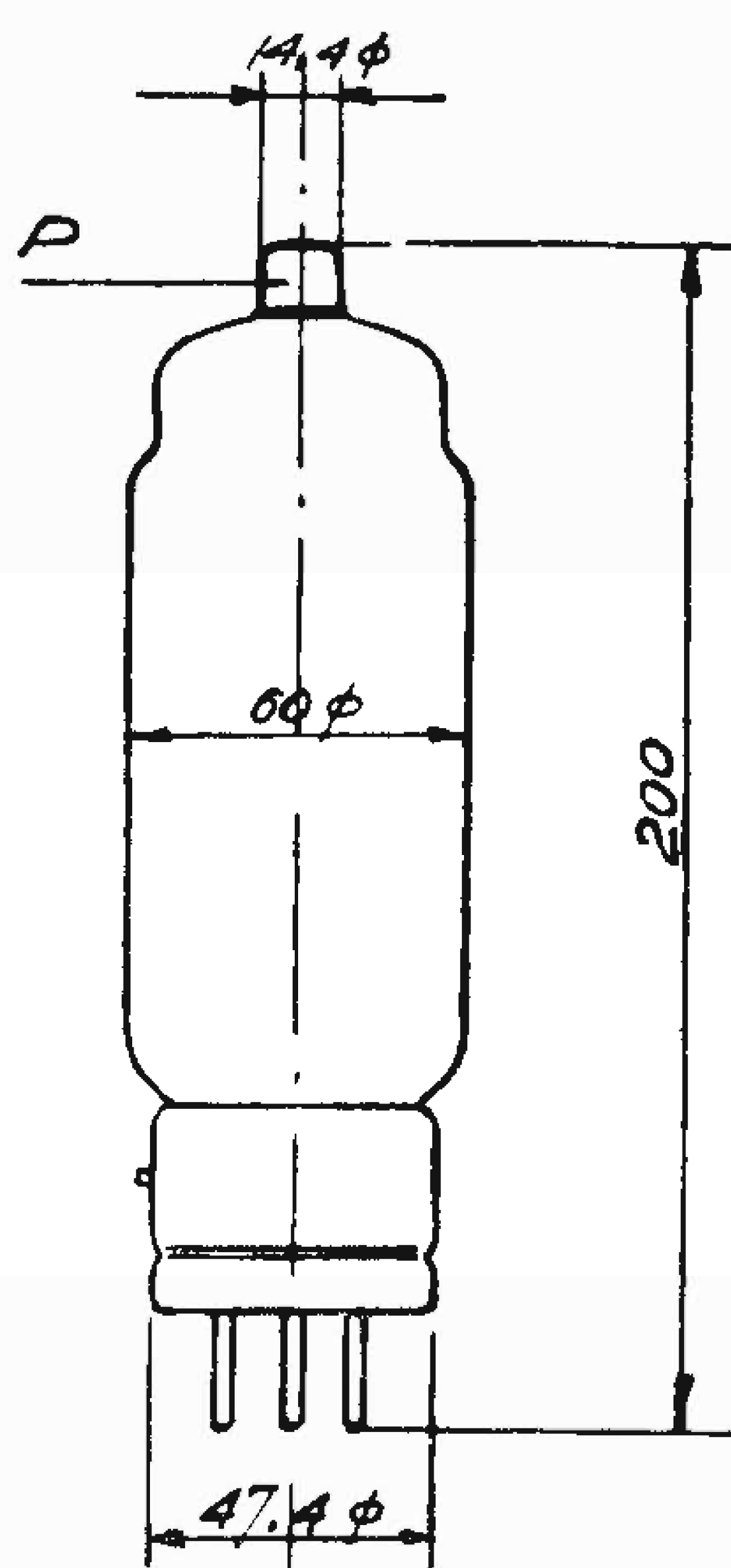
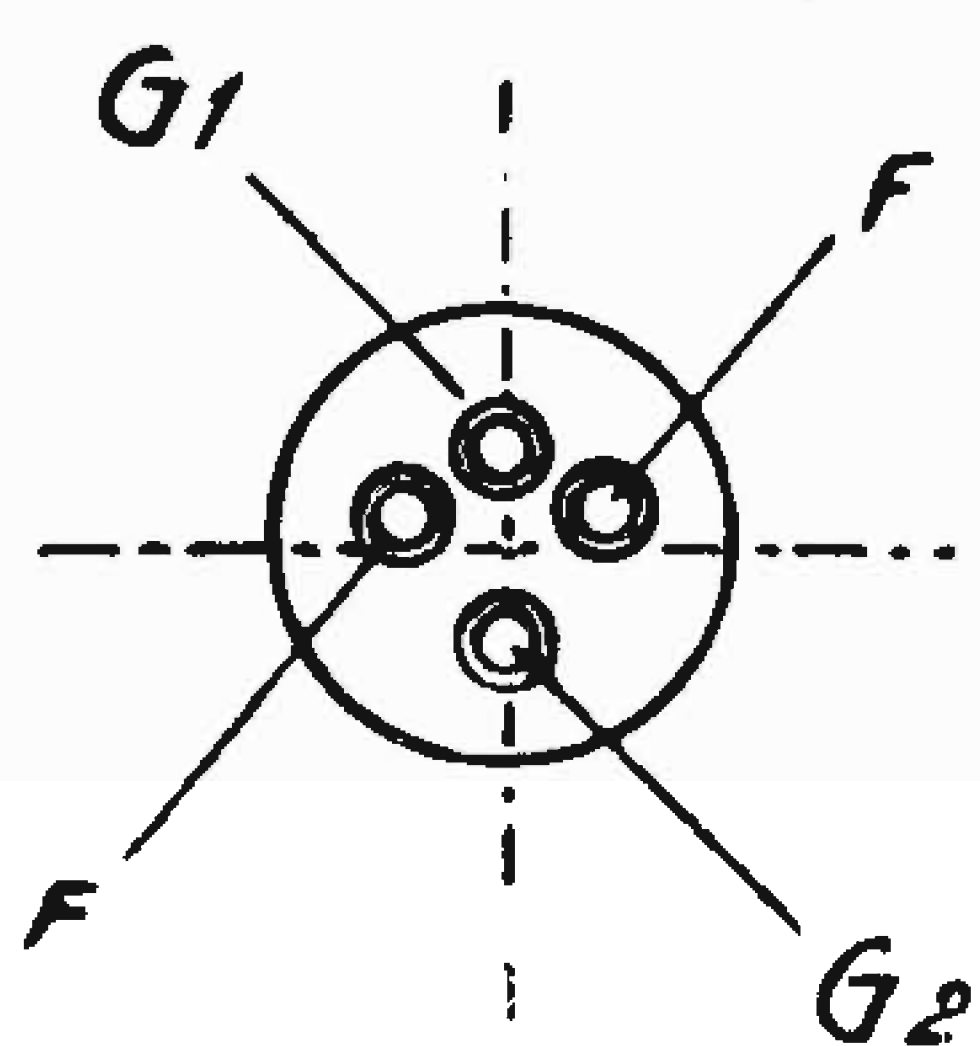

Fig. 9 a

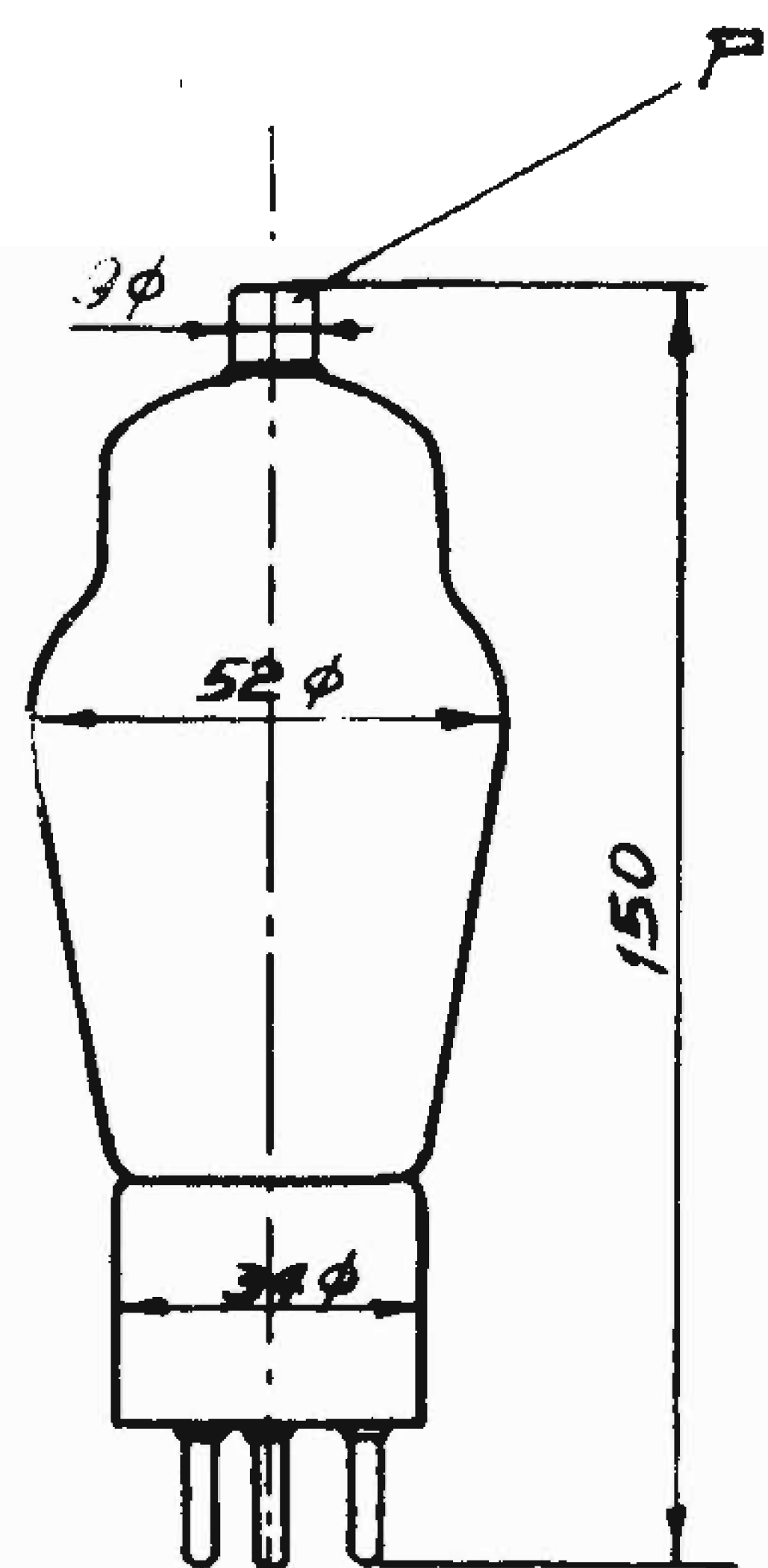
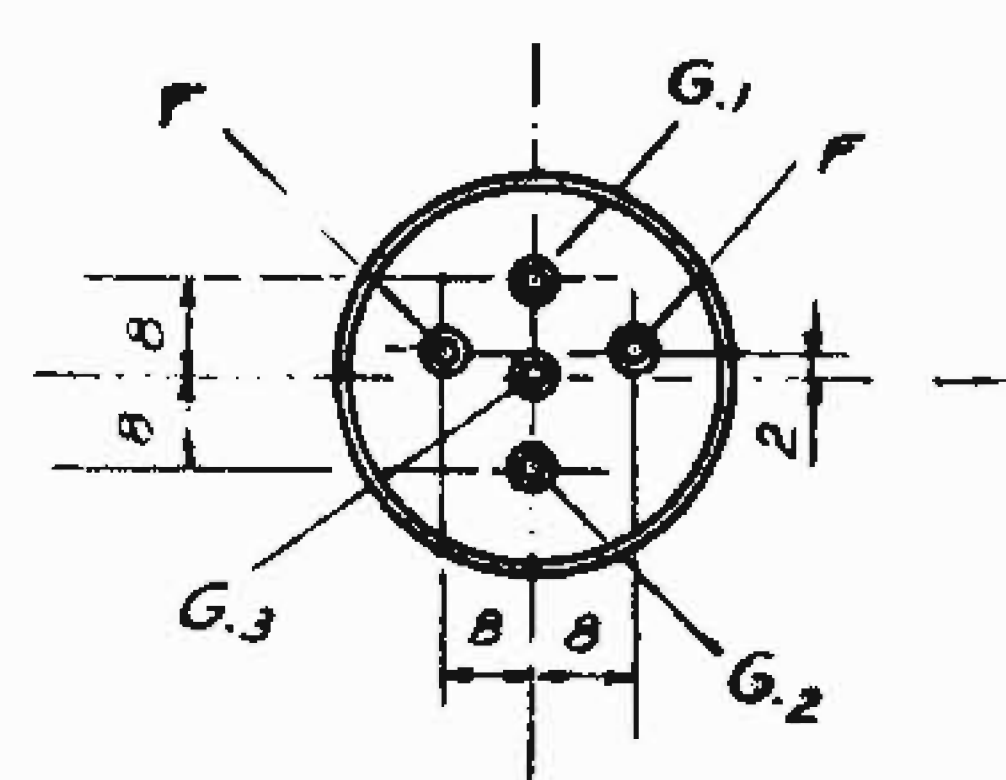

Fig. 8

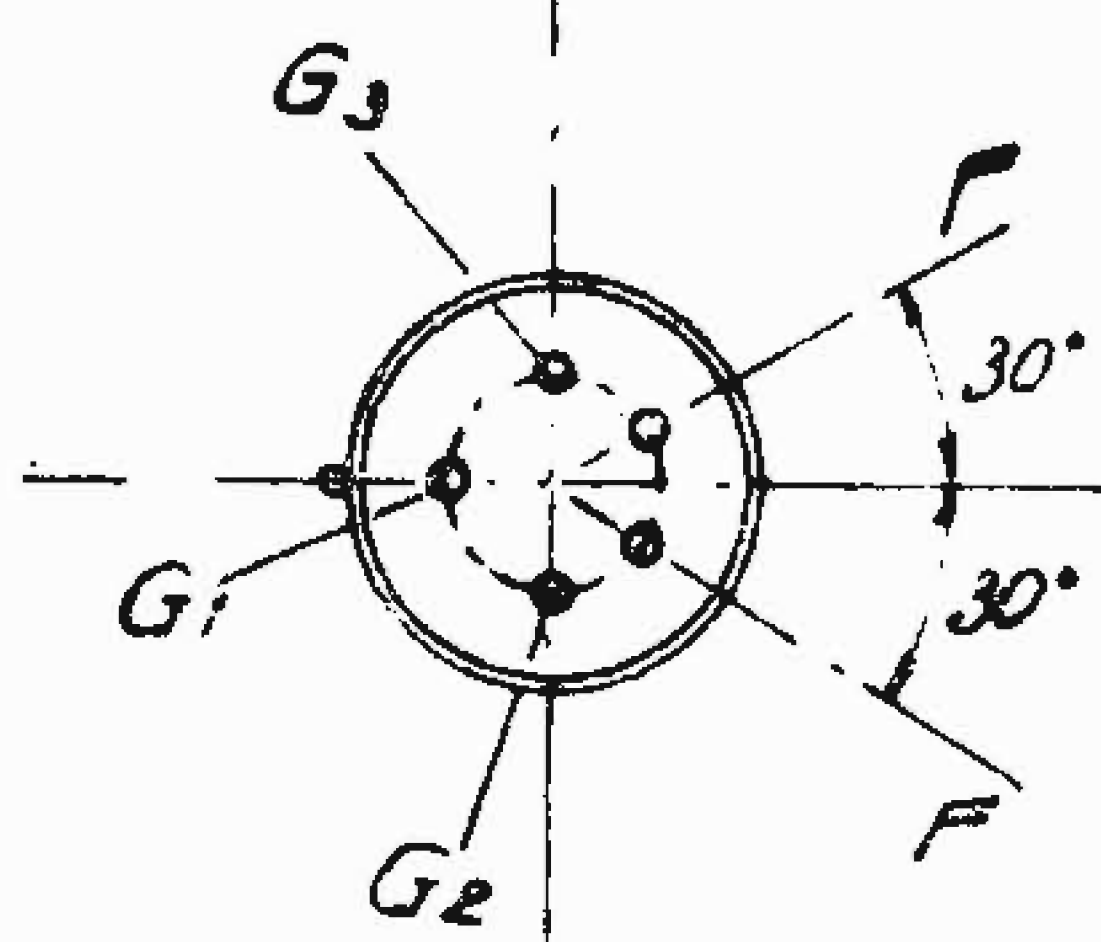
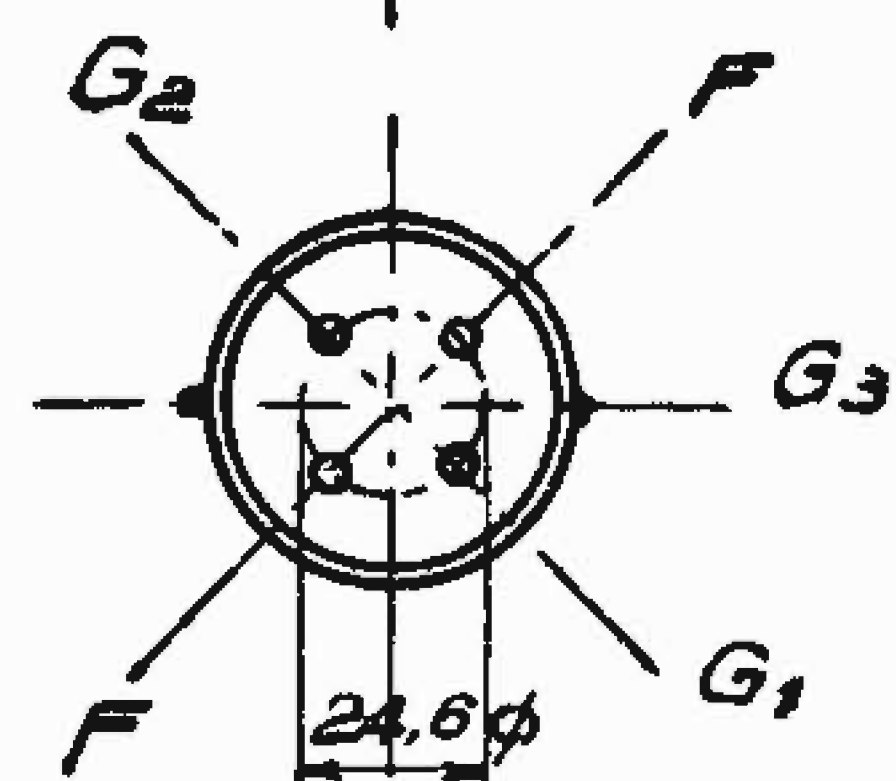
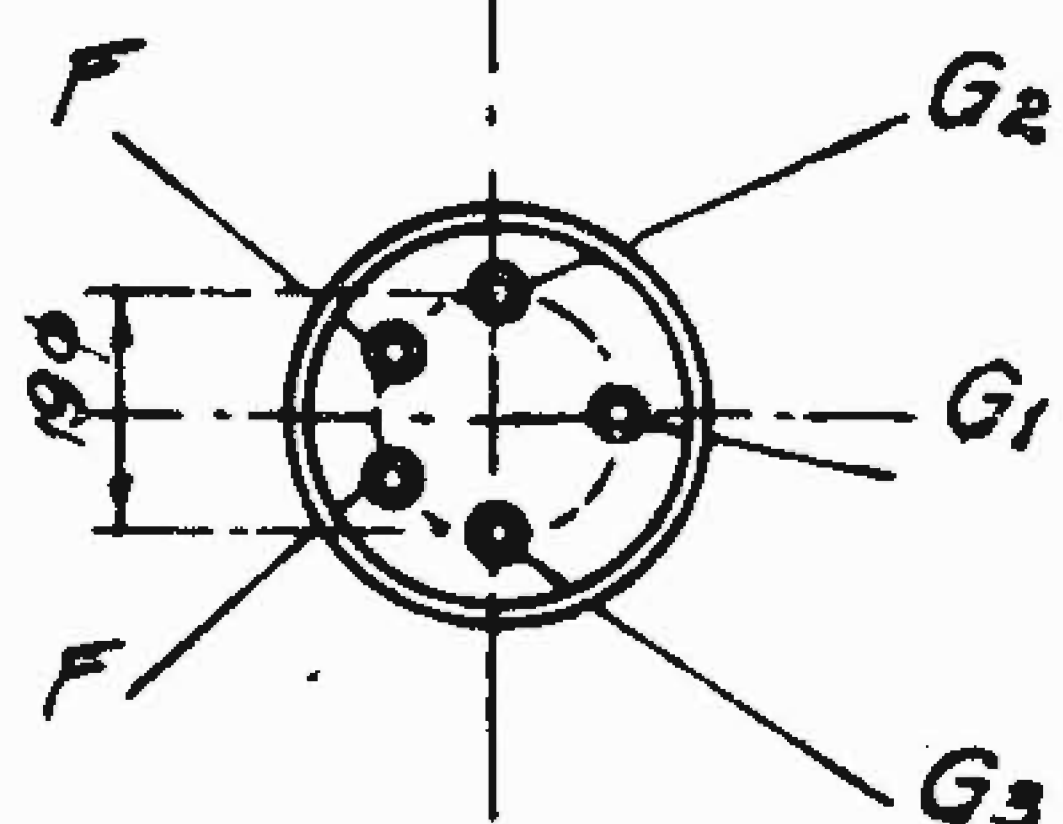
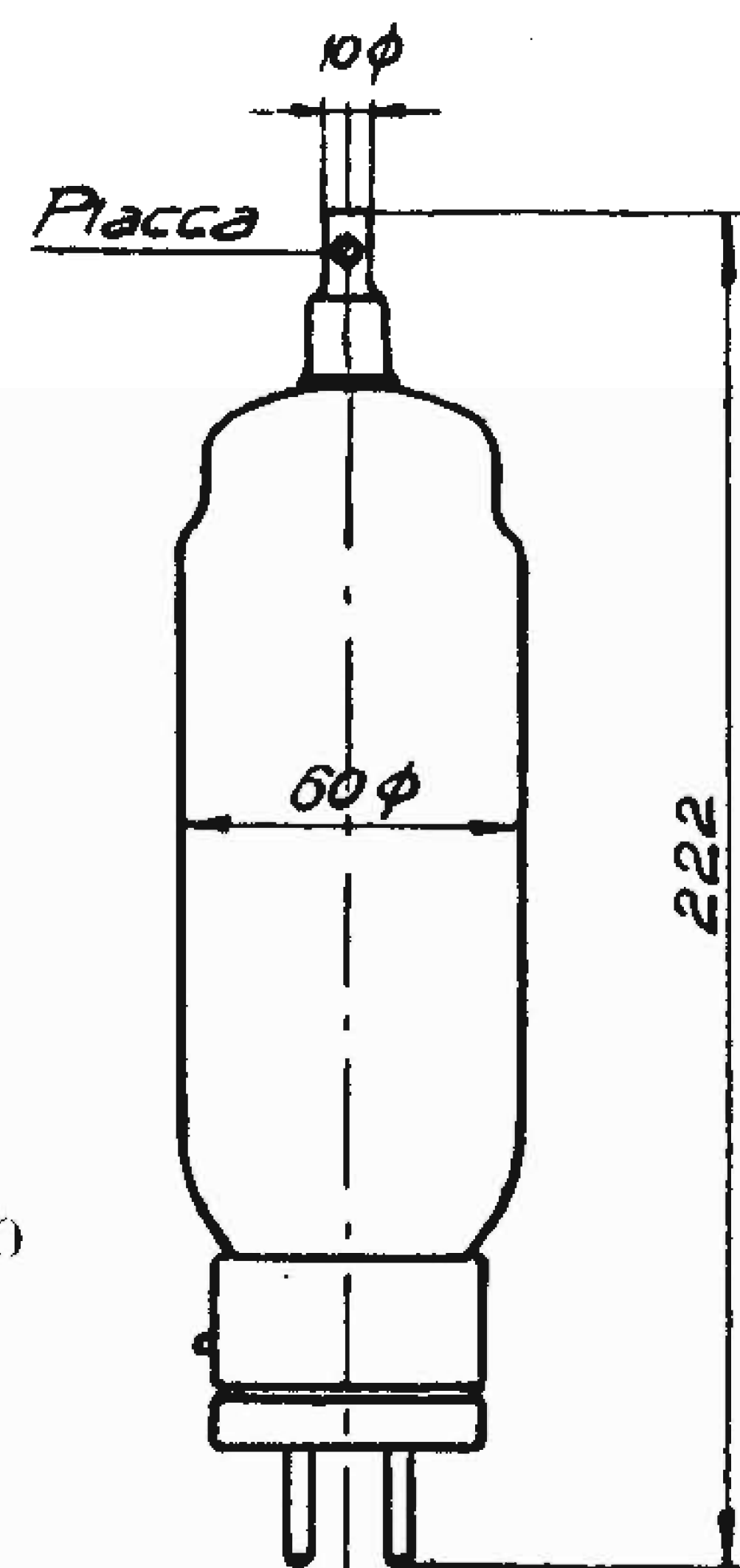

Fig. 9 b



DIMENSIONI DEI TUBI TRASMETTENTI « FIVRE »

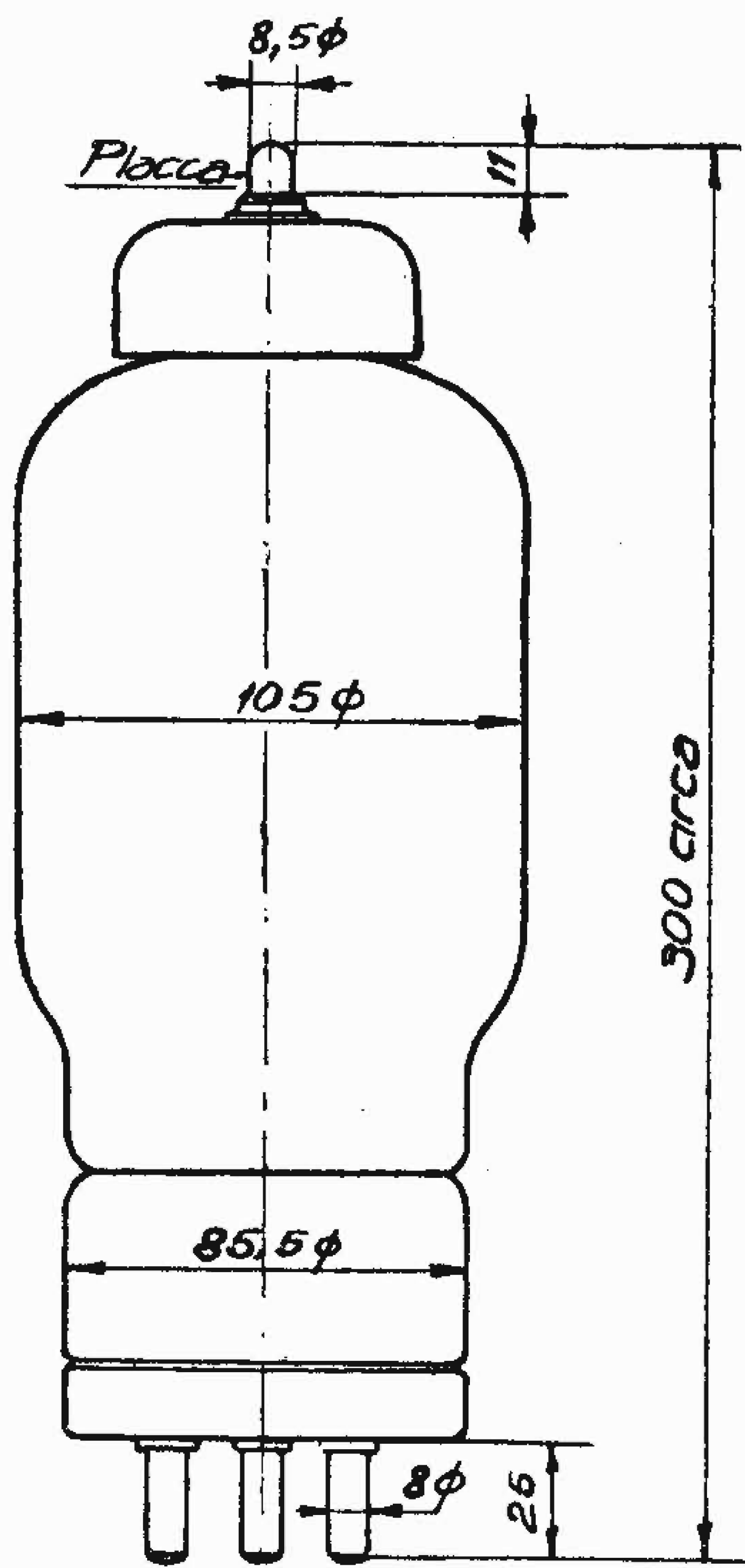

Fig. 10

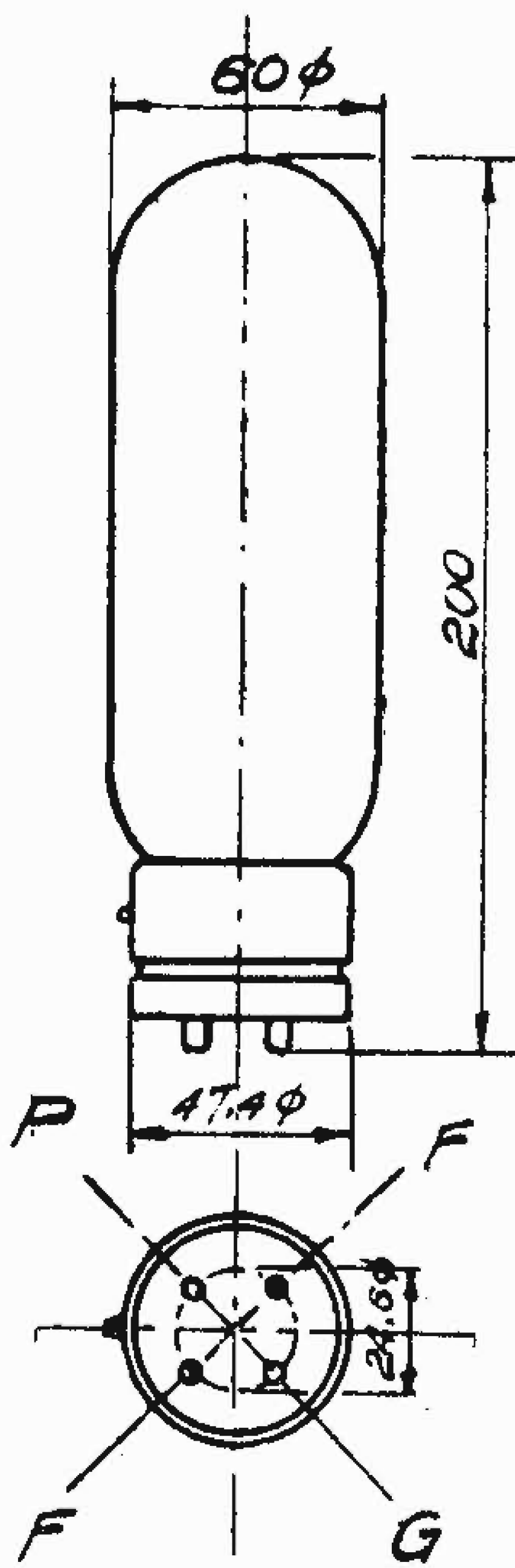

Fig. 11

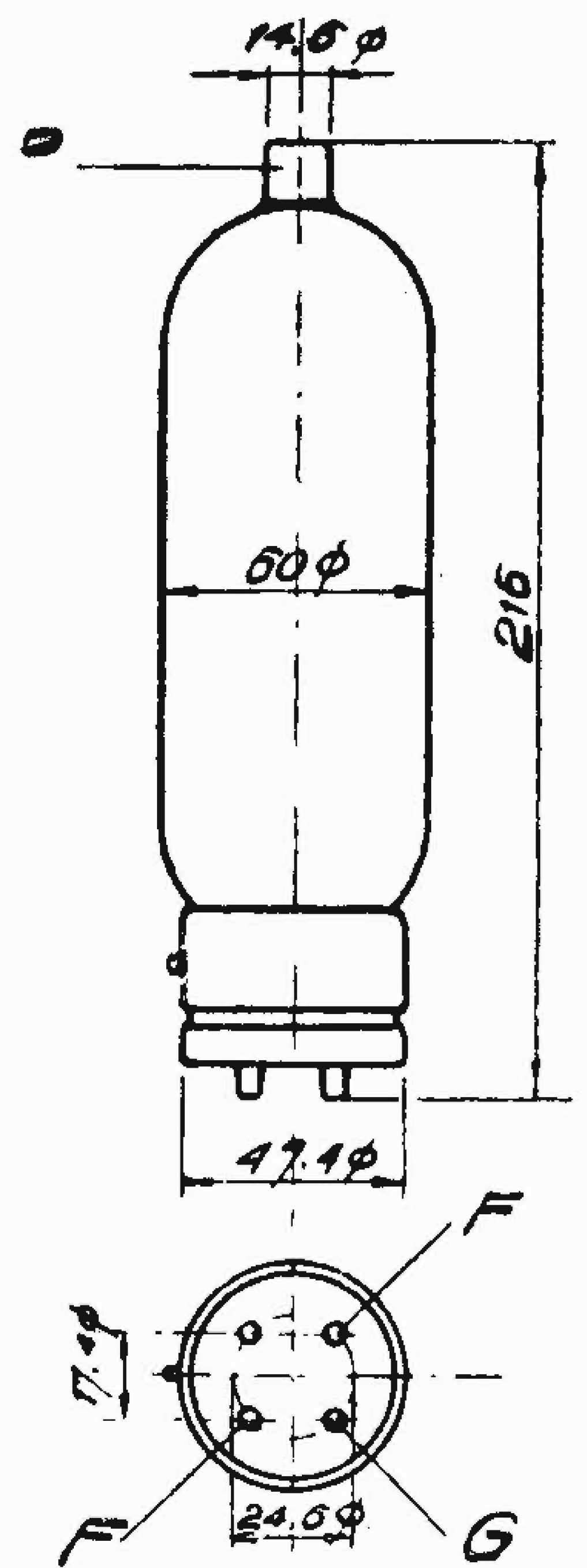

Fig. 12

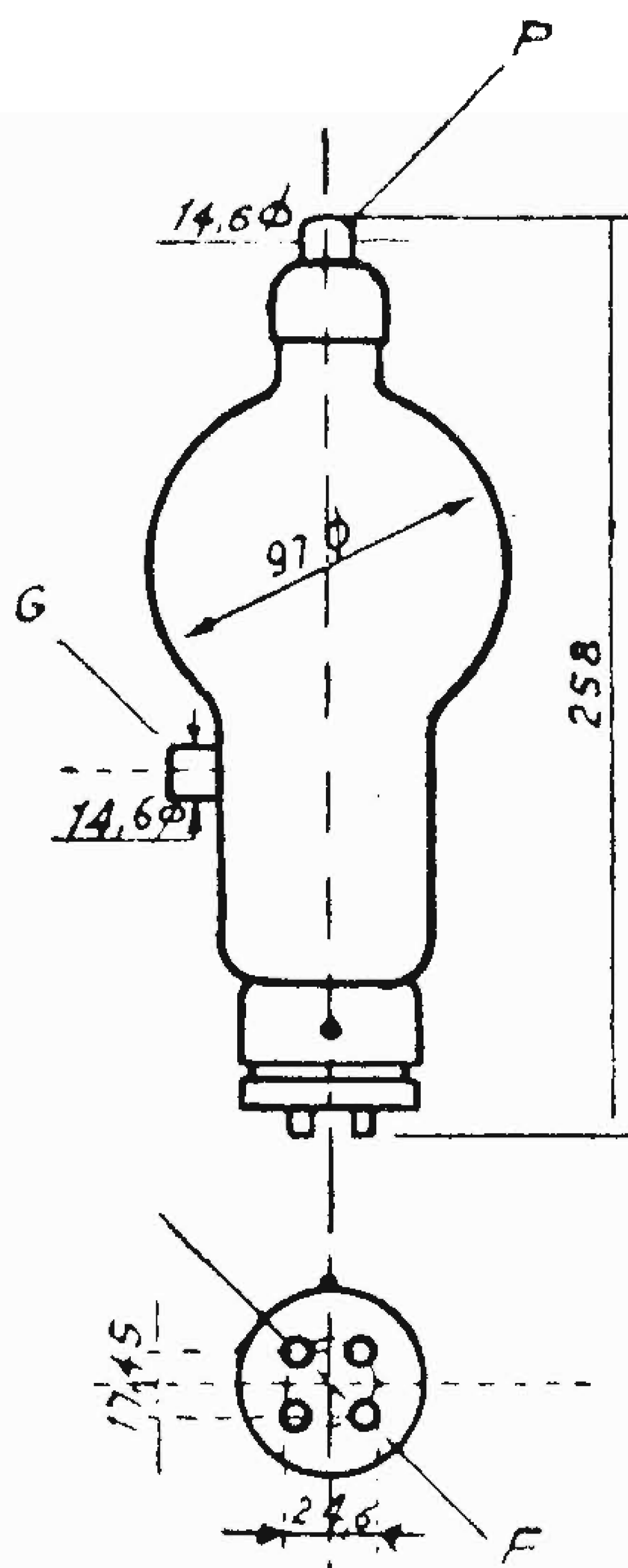
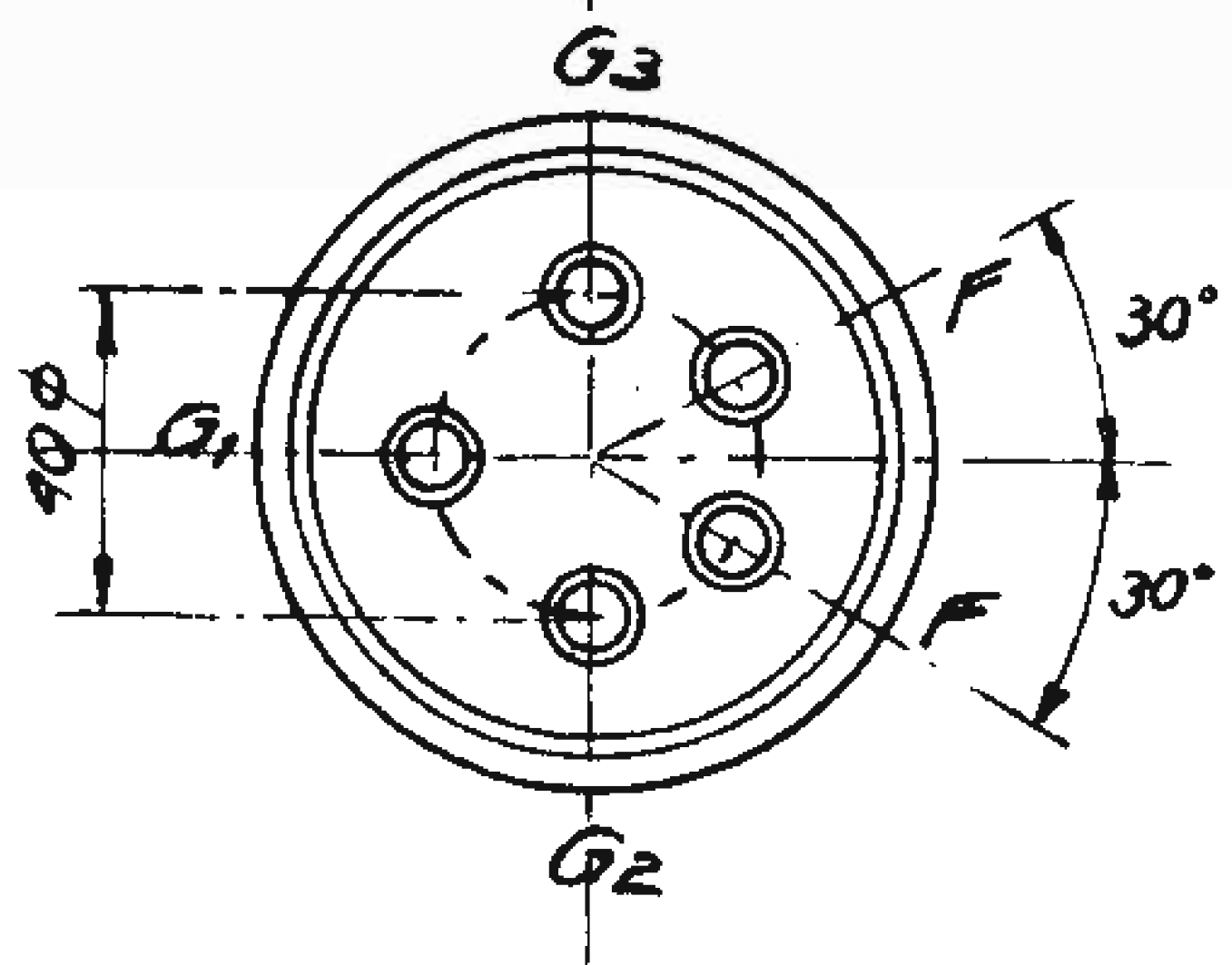

Fig. 13

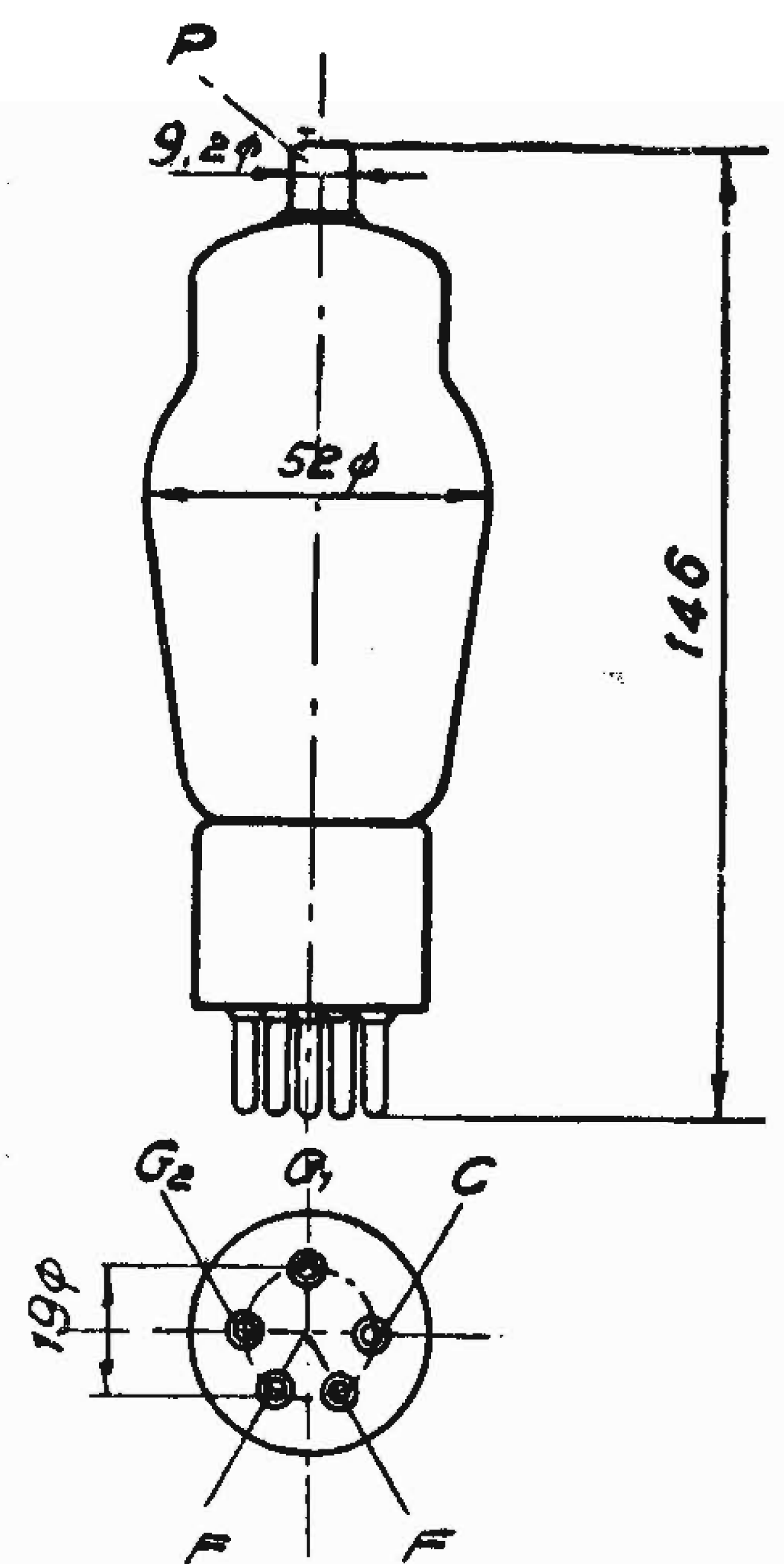

Fig. 14

DIMENSIONI DEI TUBI TRASMETTENTI « FIVRE »

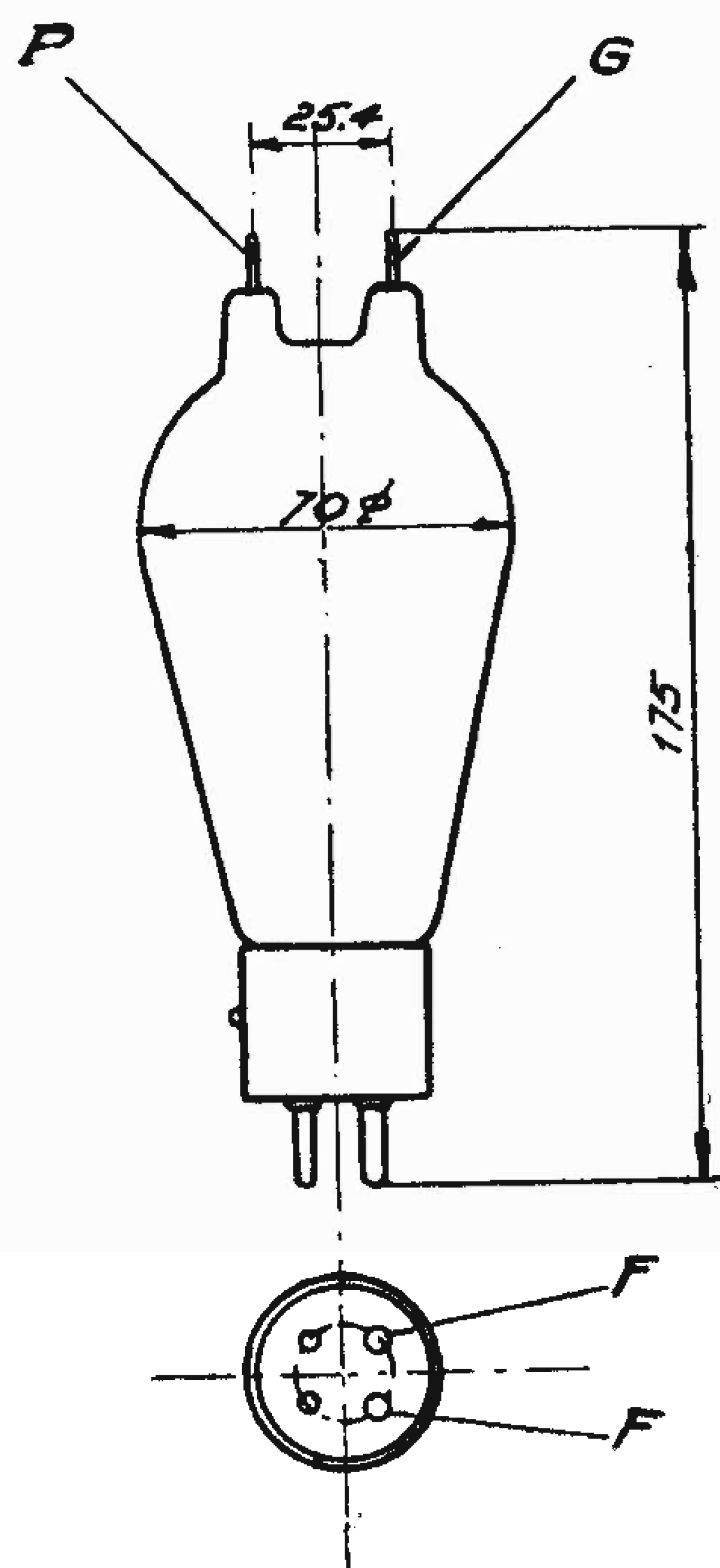

Fig. 15

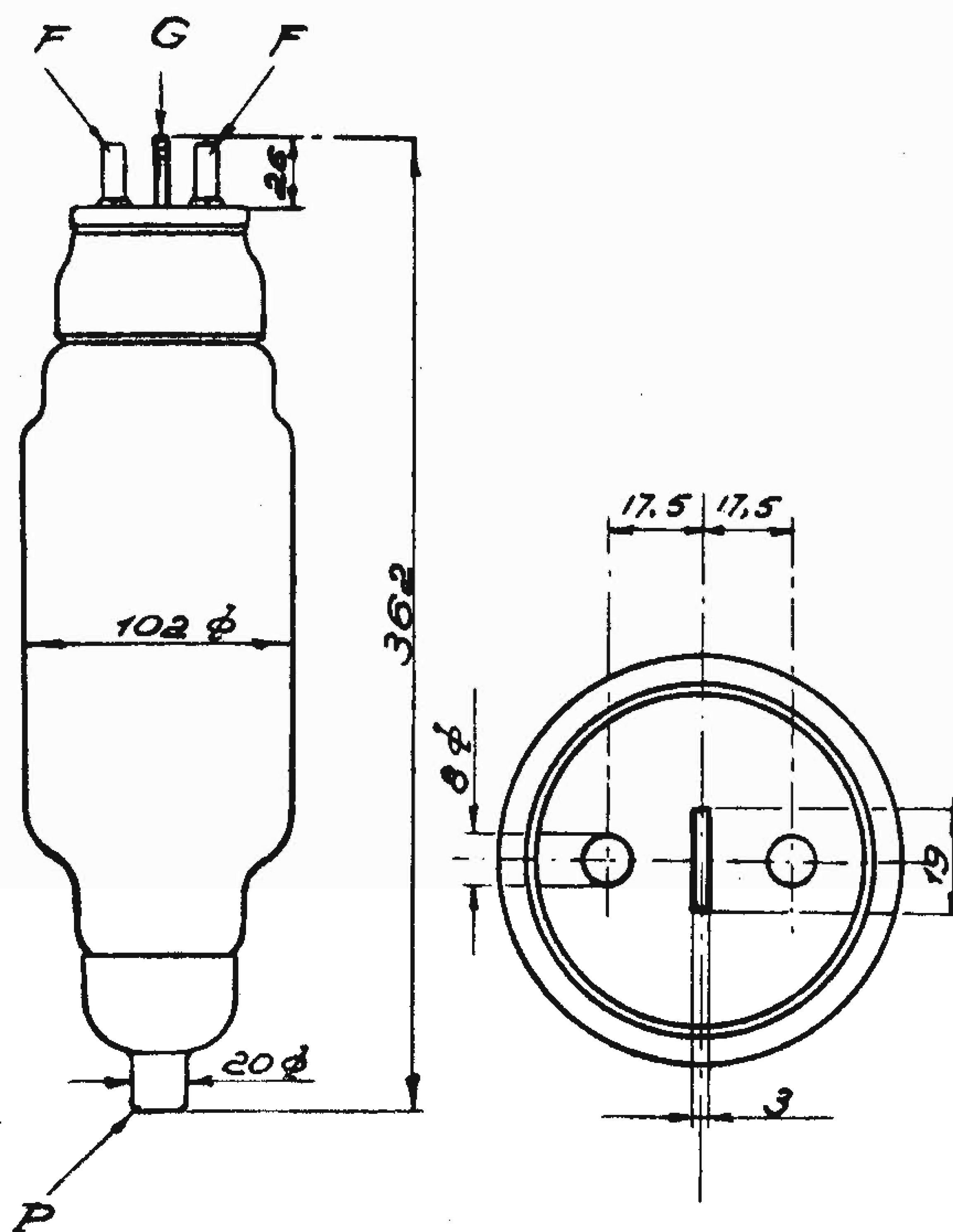

Fig. 16

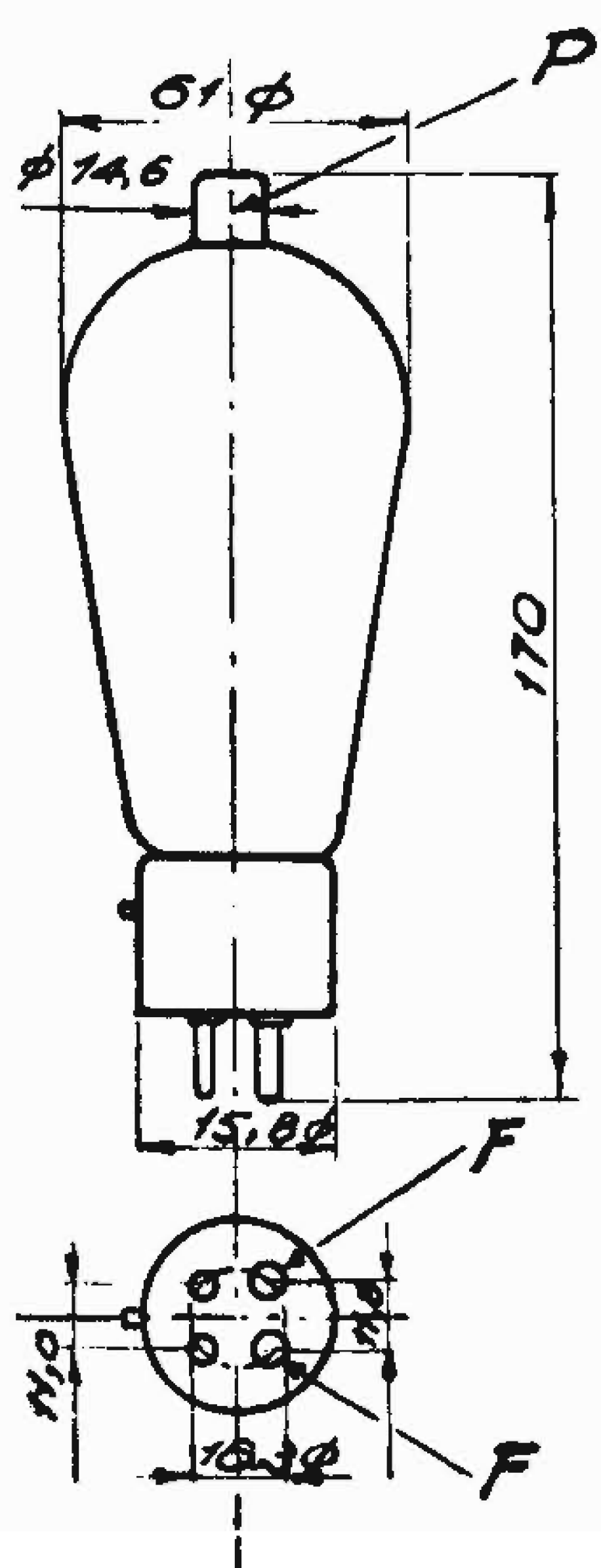

Fig. 17

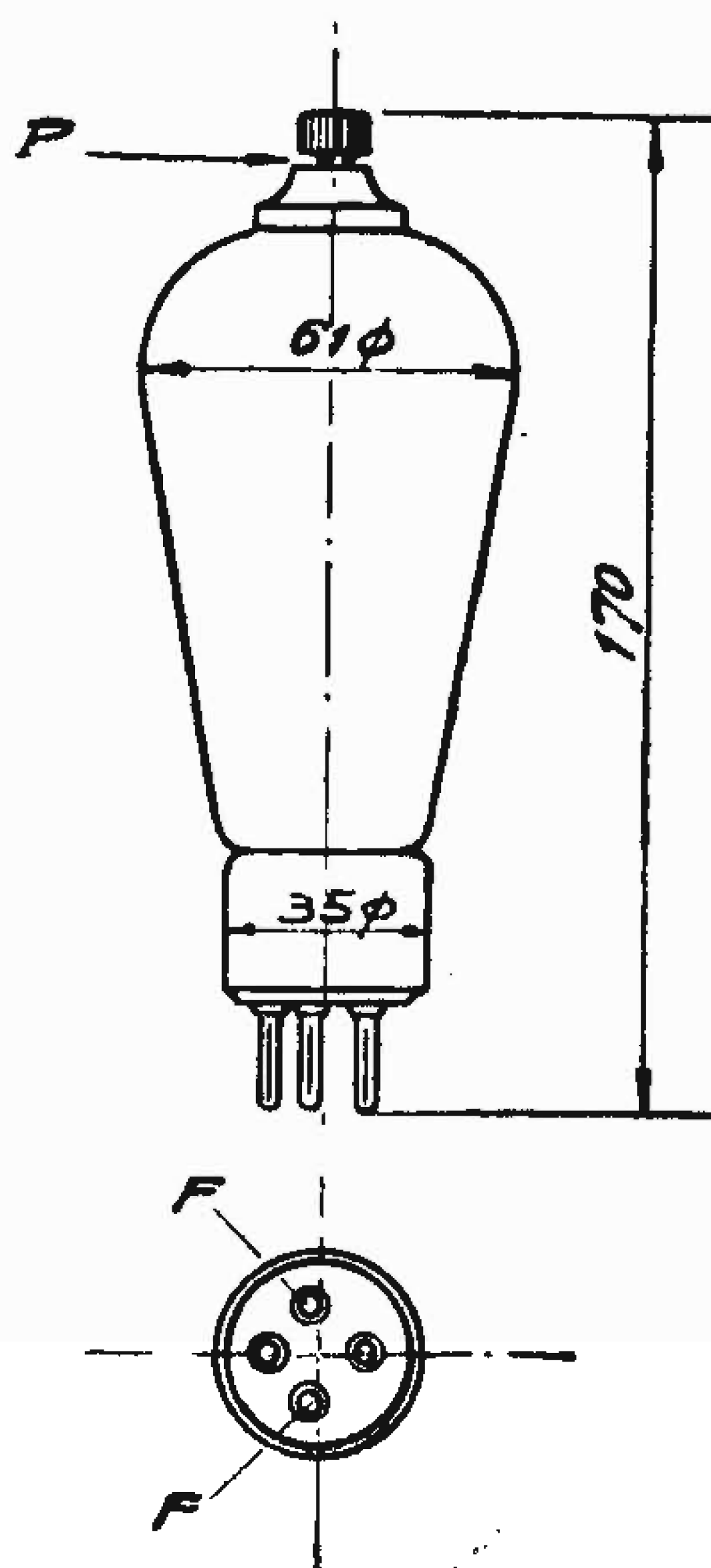

Fig. 18

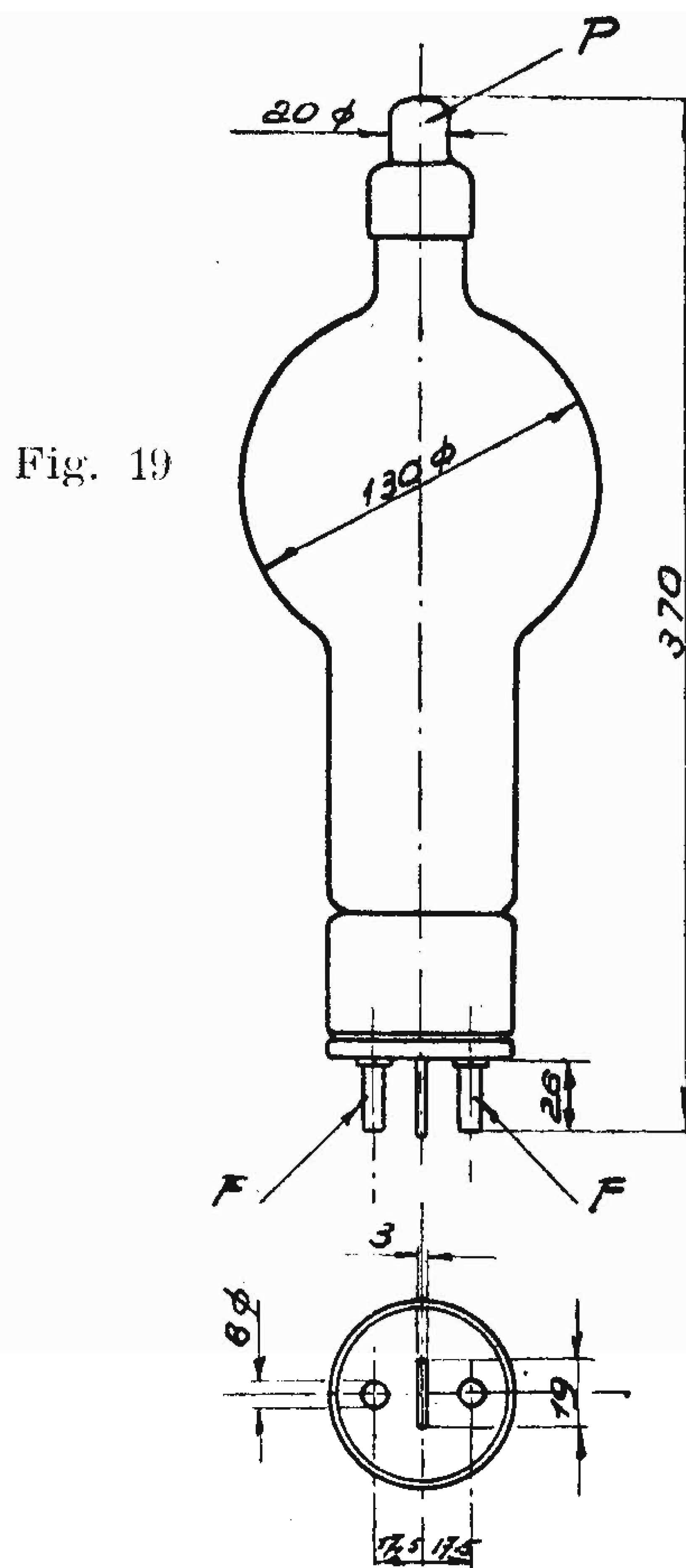

Fig. 19

DIMENSIONI DEI TUBI TRASMITTENTI « FIVRE »

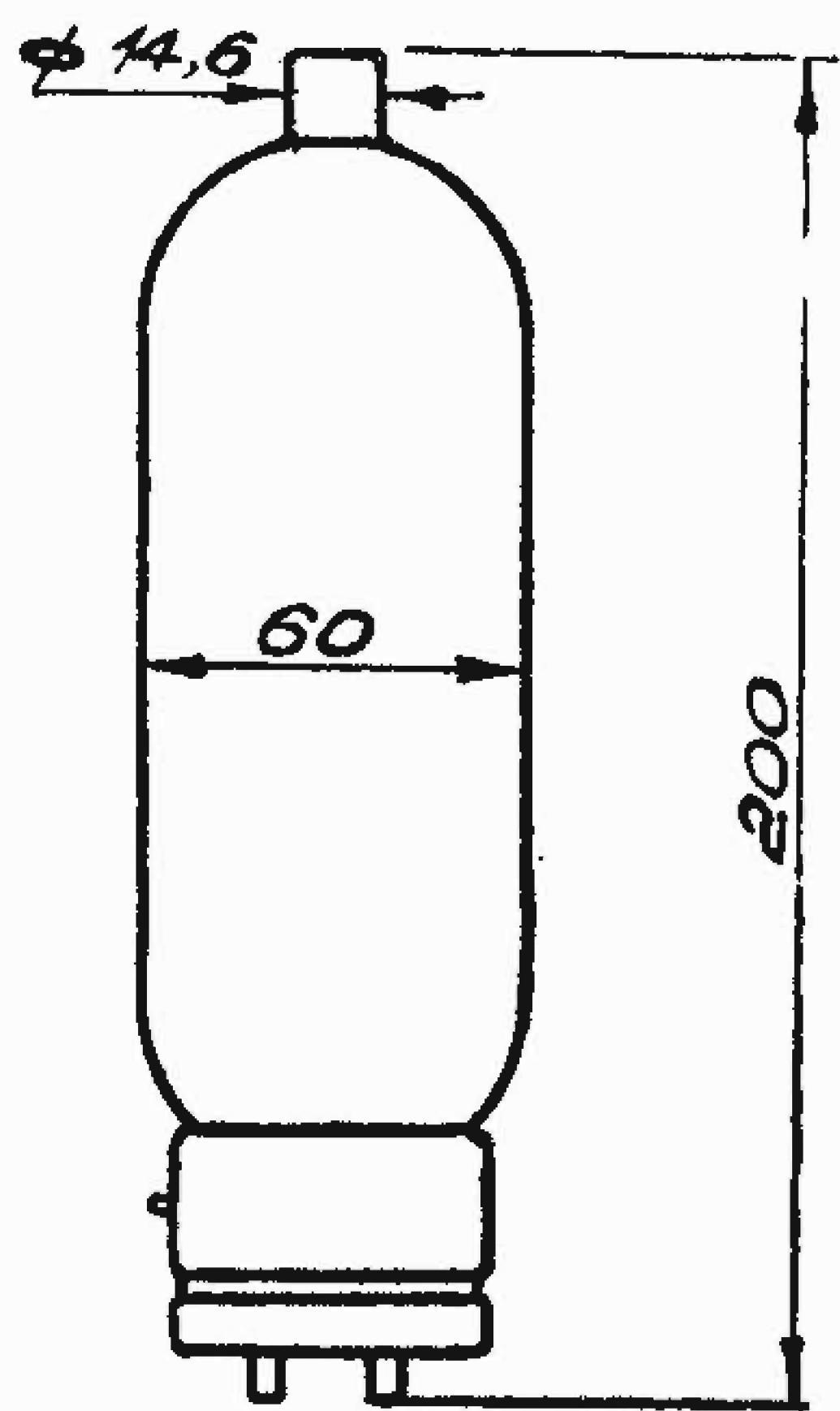

Fig. 20

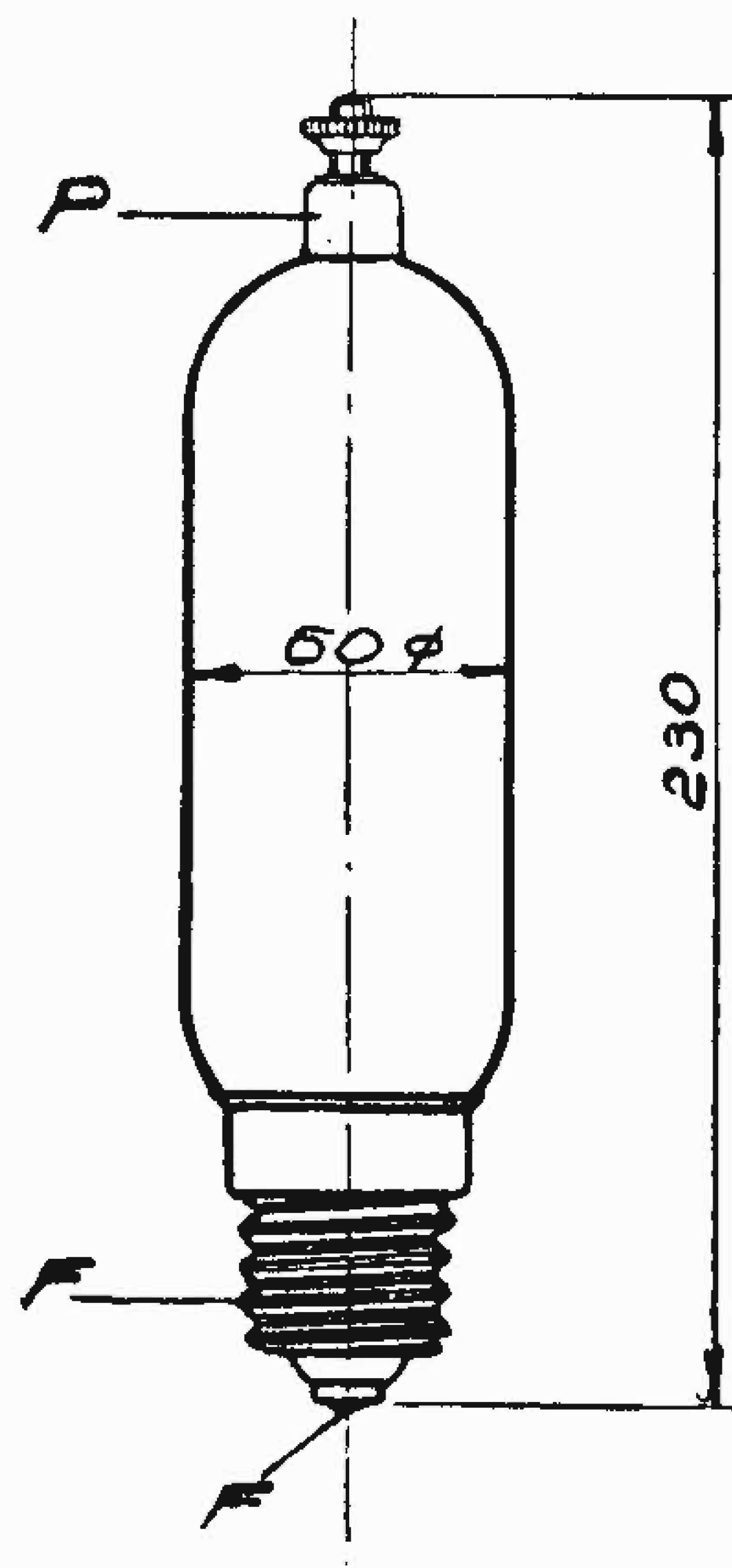
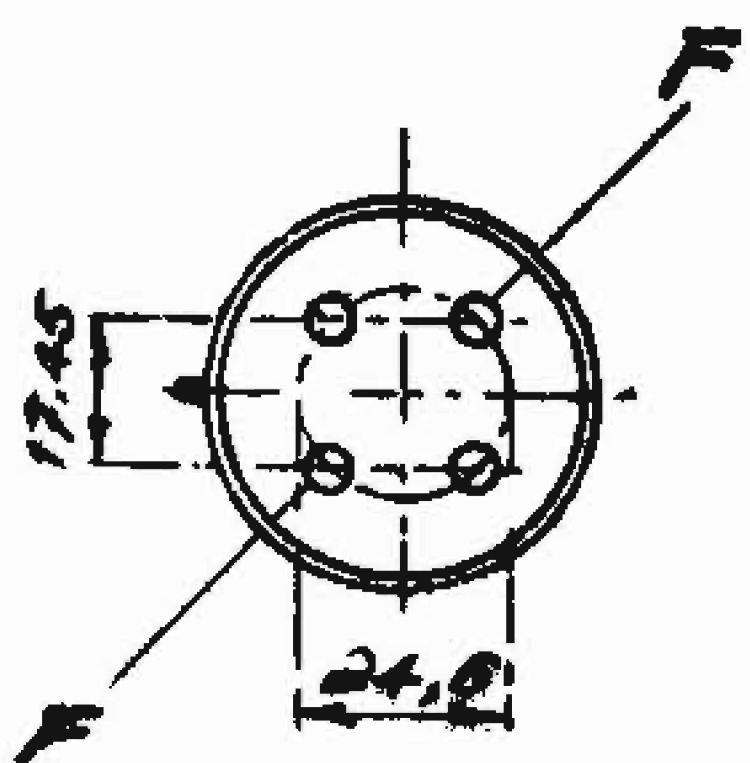

Fig. 21

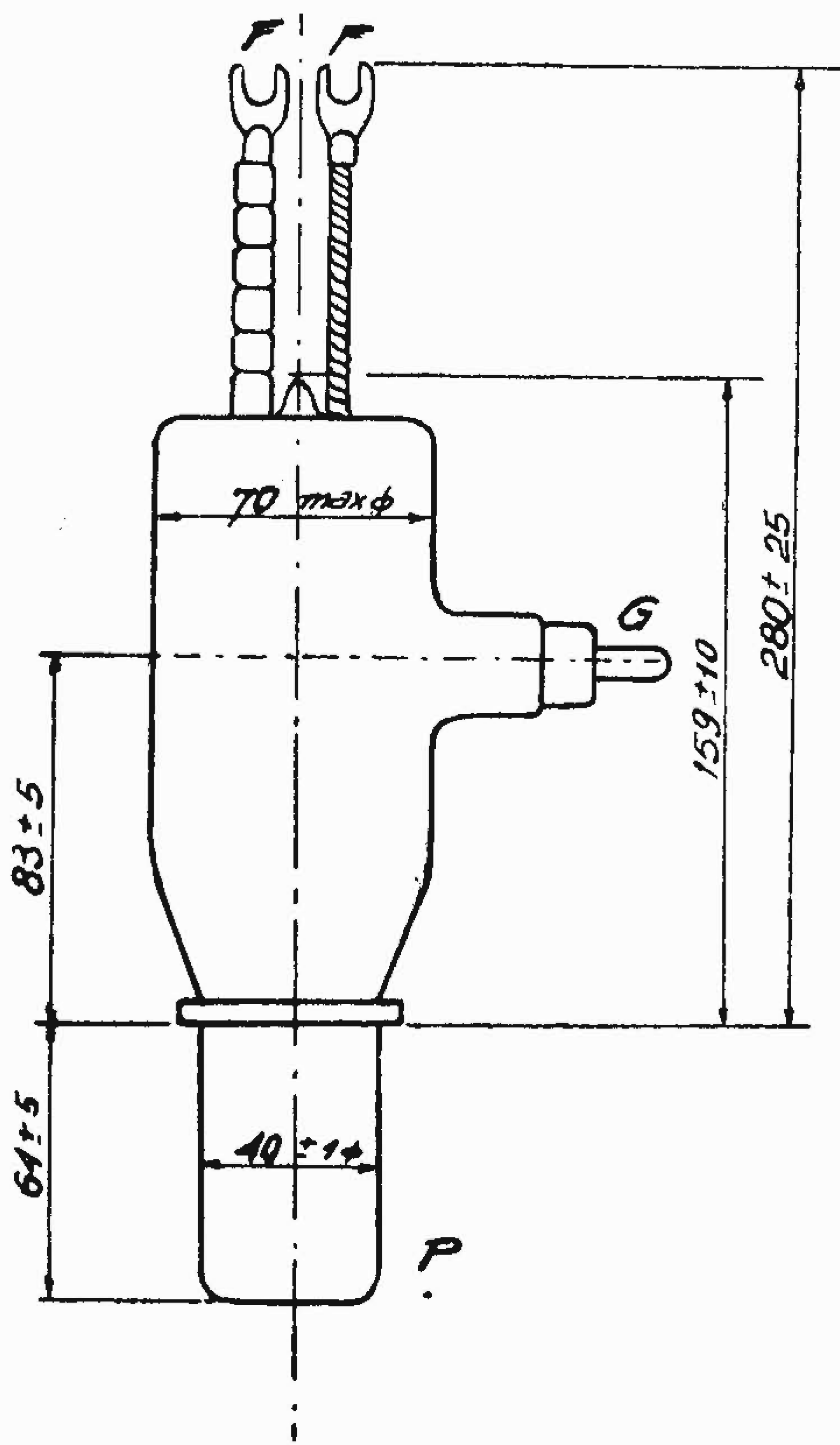

Fig. 23

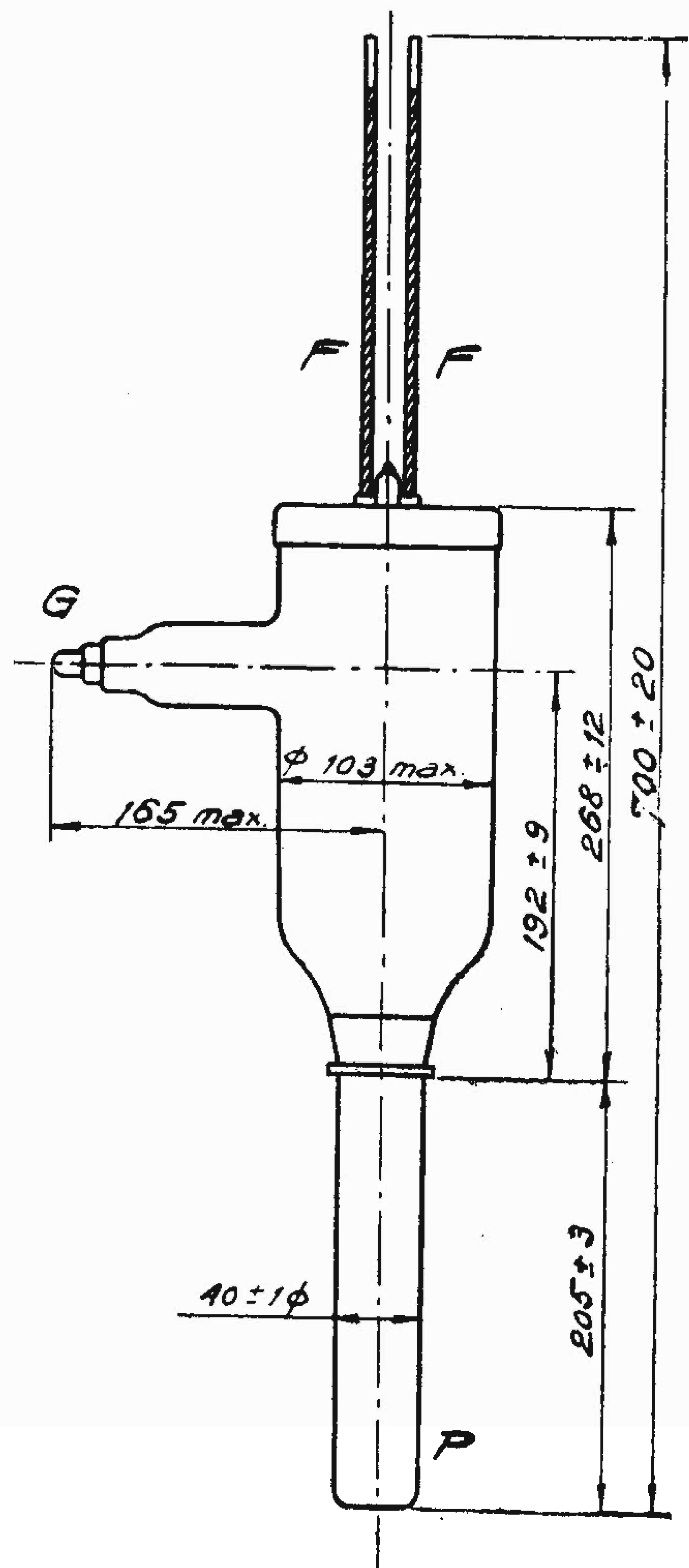

Fig. 22

DIMENSIONI DEI TUBI TRASMITTENTI « FIVRE »

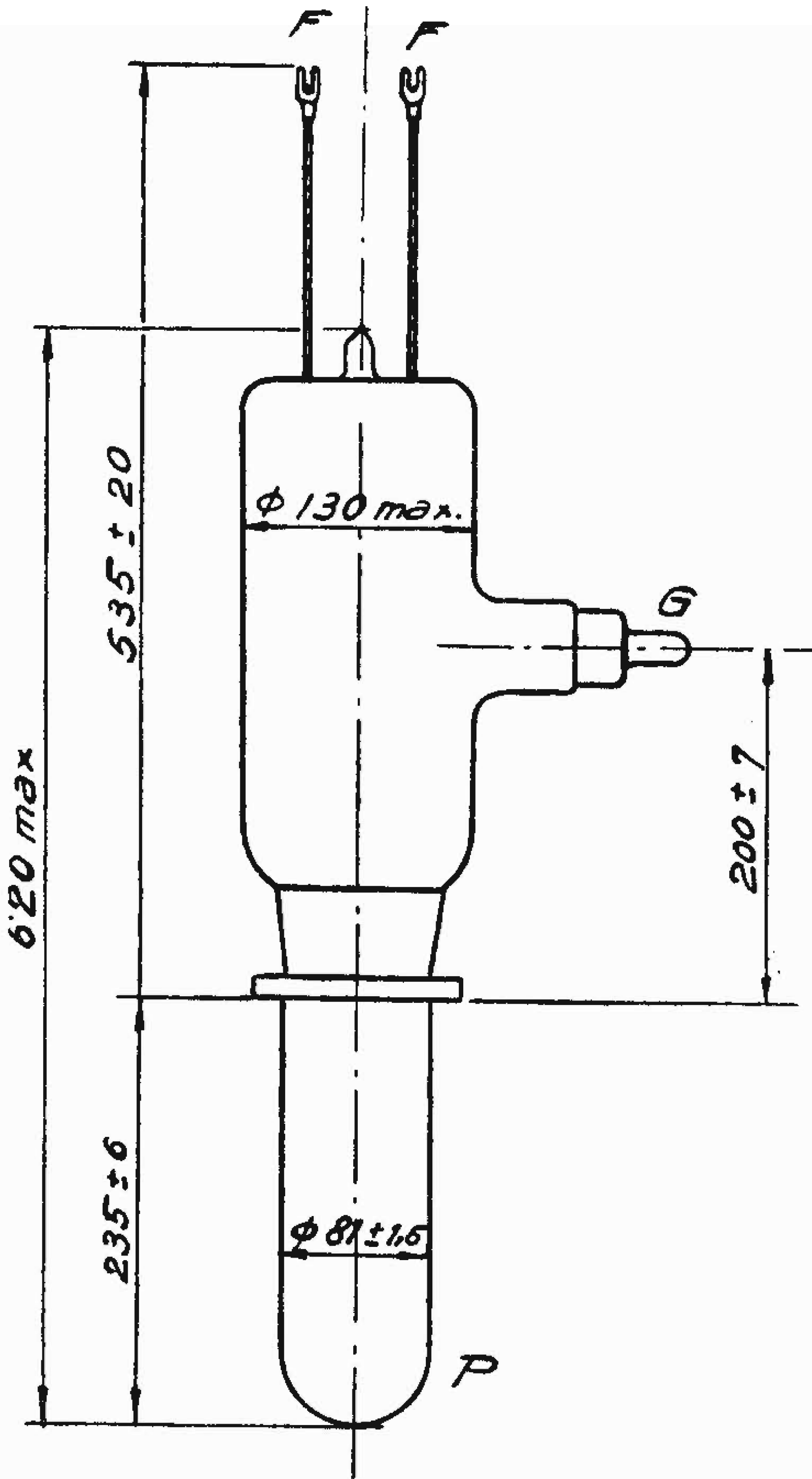

Fig. 24

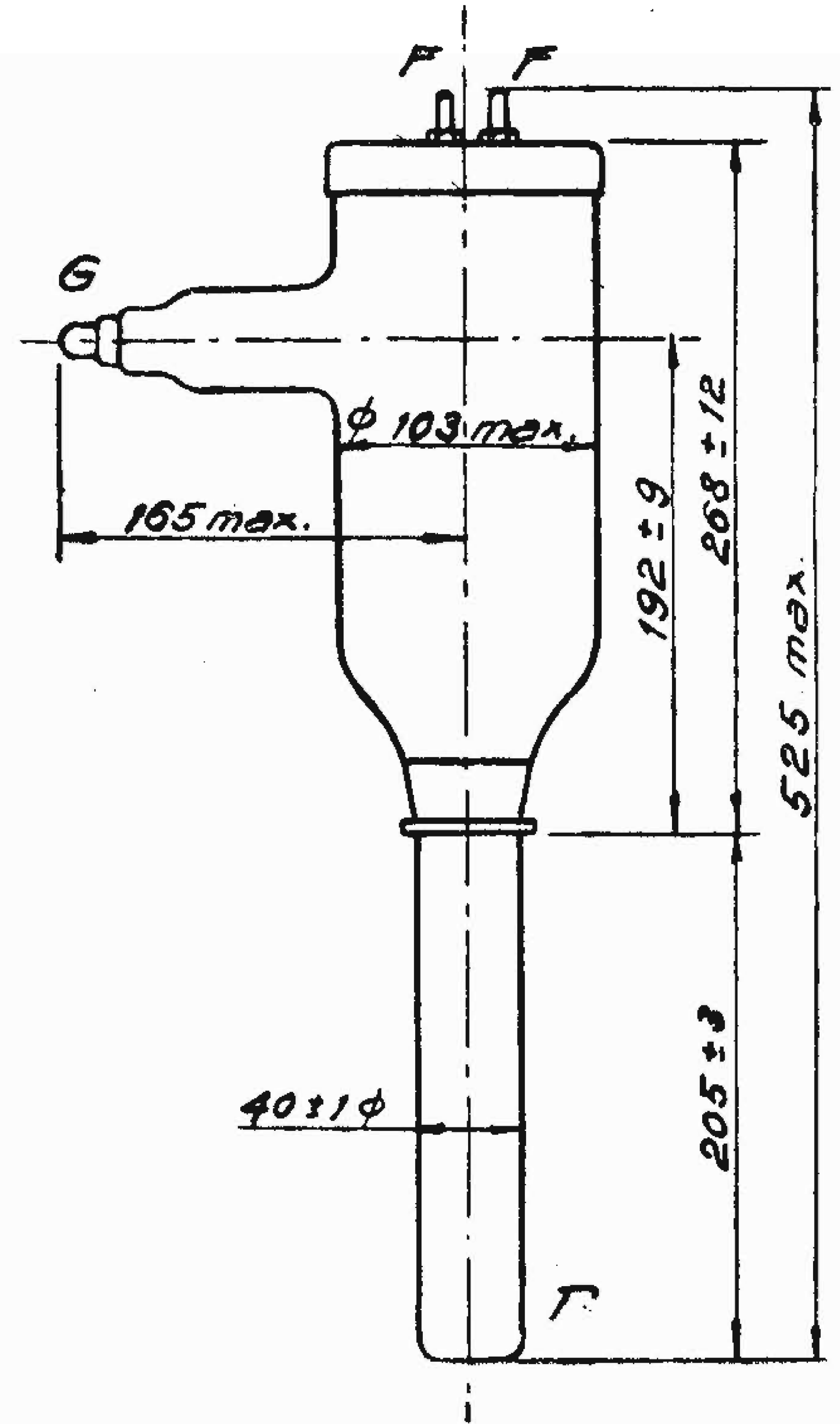

Fig. 25

